

Automatic Success

CO₂ Blast Cleaning With CRYOCLEAN[®] snow

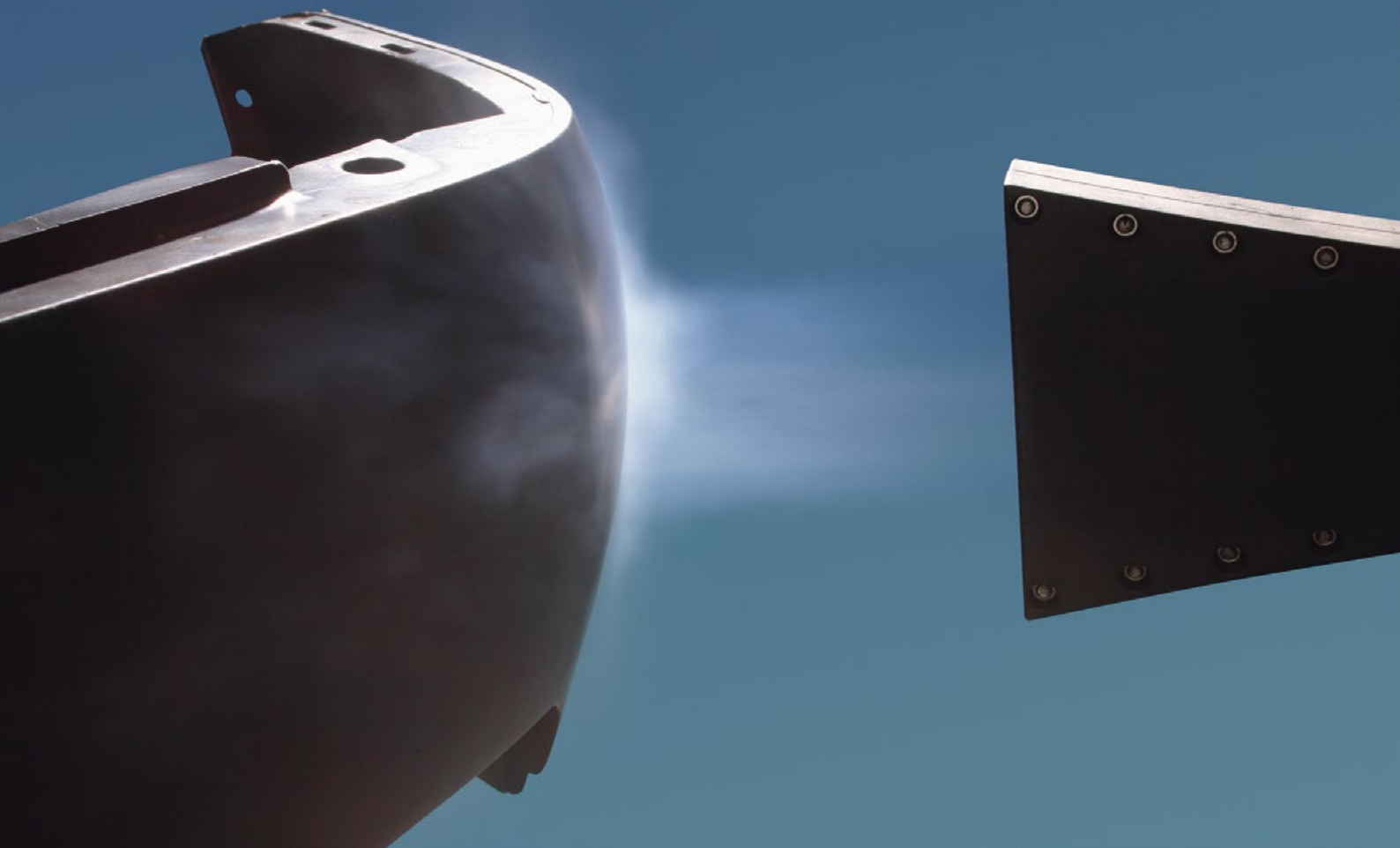

Snow magic with CRYOCLEAN[®]snow. Fully automated surface cleaning.

Over the years, CO₂ blast cleaning has been established as a standard method in various areas of industrial cleaning. In addition to blast cleaning with dry ice pellets, BOC offers an attractive fully automated alternative with dry ice snow: CRYOCLEAN[®]snow. This blasting system produces CO₂ snow particles directly on demand from a liquid CO₂ supply. Even though it is less aggressive than conventional processes, it is advantageous for many applications as it requires no handling of dry ice pellets and little maintenance.



CRYOCLEAN®snow is based on a fundamentally new functional principle. By feeding liquid CO₂ (LIC) into a specially designed device, particularly solid snow particles are produced and "shot" immediately onto the surface with compressed air. The system is designed for medium-power cleaning processes and a layer thickness up to approximately 1 mm.

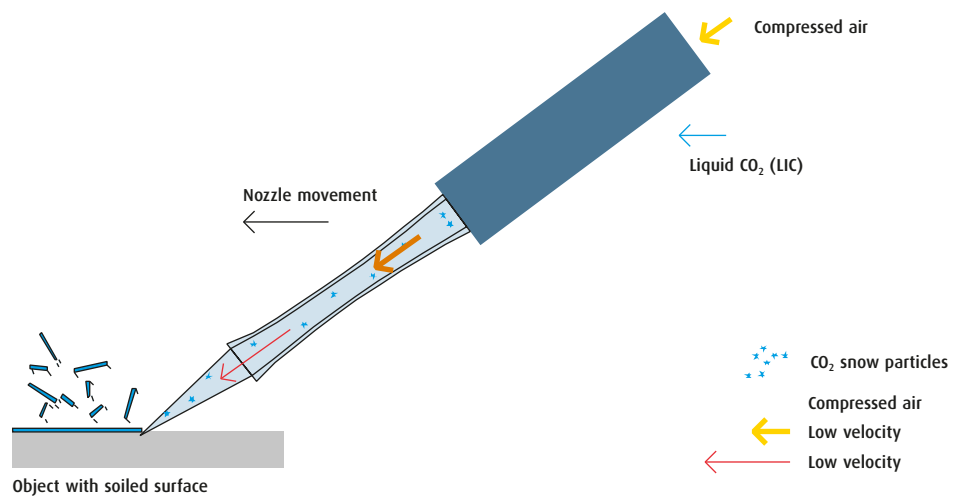

The proven benefits of CRYOCLEAN®

CRYOCLEAN®snow is similar to conventional CO₂ blast cleaning when it comes to efficiency and eco-friendliness:

- The cleaned surfaces have a particularly high quality.
- As the CO₂ snow sublimates directly after use, there are no cleaning agent residues left.
- The safety of the workplace is enhanced as no harmful solvents are used.
- Several square metres can be cleaned per minute.

Benefits of CRYOCLEAN®snow

In contrast to conventional CO₂ blast cleaning, CRYOCLEAN®snow does not require dry ice pellets, which has the following benefits:

- Clumped pellets will no longer cause malfunctions of the blasting unit.
- No personnel are needed for the refilling of pellets or other tasks.
- Purchase, storage and handling of pellets is not required.
- As liquid CO₂ (LIC) can be easily stored for long periods, the cleaning power is immediately available.

Recommended applications

CRYOCLEAN®snow can be integrated into the production process and offers the perfect solution for the full automation of cleaning processes, such as for example:

- Surface pretreatment for lacquering, coating, gluing, etc.
- Surface cleaning before and after welding
- Mould cleaning in various production processes
- Surface cleaning in the electronic and semiconductor industry



A valuable product with unique abilities. Interesting facts about CO₂.

CO₂ is important for life

Life on earth would not be possible without carbon dioxide (CO₂). In the continuous atmospheric cycle, it is released and absorbed over and over again – e. g. by processes such as photosynthesis. This keeps the greenhouse effect at a constant level. The combustion of fossil fuels, however, increases the amount of carbon dioxide, which disrupts the atmospheric cycle. This is the reason why many people associate carbon dioxide with global warming and consider it negative overlooking its general importance.

CO₂ and the environment

Contrary to popular belief, the use of industrially produced CO₂ does not contribute to global warming as carbon dioxide can be recovered from production residues and by-products of combustion and chemical processes in the production of ammonia, alcohols and fertilisers. This carbon dioxide would be released directly into the atmosphere if BOC did not “capture” it and turned it into a valuable product.

In many applications, carbon dioxide replaces substances which have a negative impact on the environment – for example, halons in fire

extinguishers and freons (CFCs) in the production of polystyrene and polyurethane foams. These substances destroy the ozone layer in the stratosphere and are therefore forbidden from use. In swimming pools, carbon dioxide instead of hydrochloric acid is used to neutralise the water. The risk of harmful chlorine gas being formed is thus reduced, enhancing the safety of swimmers and employees.

Hence, carbon dioxide opens up a wide variety of possible applications without harming the atmospheric cycle.

At BOC, we have extensive know-how when it comes to working with carbon dioxide. Handling this gas requires caution and a risk assessment should be conducted before using it. Please refer to the safety data sheet and safety instructions. BOC can support you with training in safe handling and storage of this and other industrial gases. For further information, please call your local BOC office.

The information contained in this document is provided as a general outline and is not intended to be a definitive statement on any subject matter. Professional advice should be sought before any action is taken in relation to safety in the workplace.

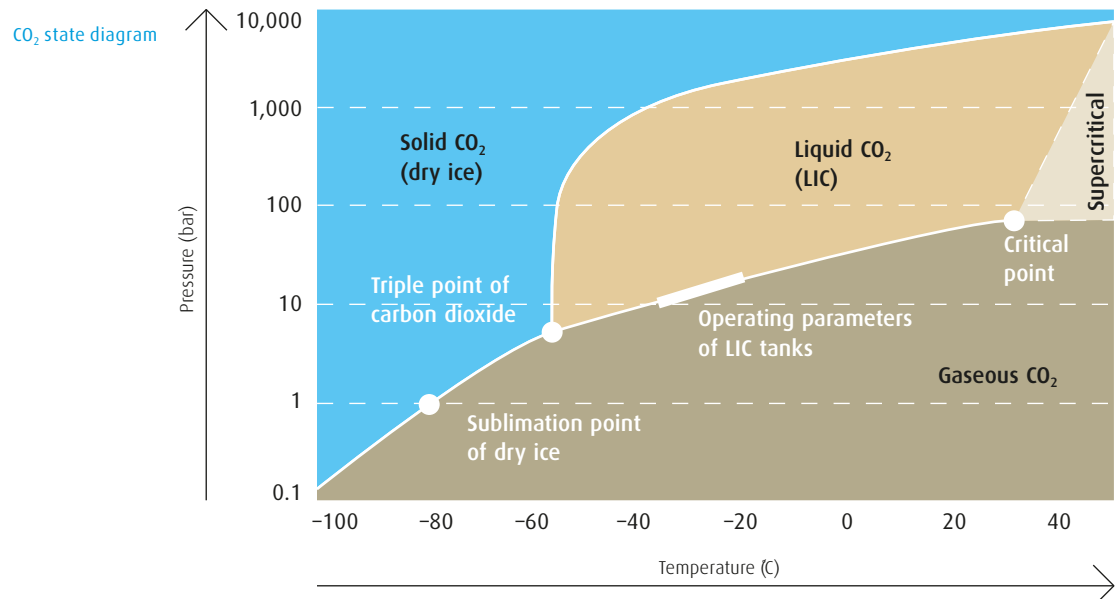

Further examples of use of CO₂

- In carbonated drinks (longer shelf life)
- For cooling or freezing of foodstuffs
- In greenhouses (increased growth rates)
- For cleaning of drinking water
- For neutralisation of waste water
- In industrial cooling processes
- As shielding gas for MAG welding of steel
- As blasting medium in CRYOCLEAN® dry ice blasting processes

Furthermore, carbon dioxide in the form of ICEBITZZZ® dry ice pellets and dry ice blocks is a highly efficient and flexible chilling agent, which keeps goods cool and fresh without additional energy.

From CO₂ snow to gas in no time flat

Liquid CO₂ is stored either in cylinders at ambient temperature under 60 bar pressure or in vacuum-insulated tanks at -20 °C under 20 bar pressure. When liquid CO₂ expands, finely powdered snow is formed. When energy is applied (e.g. heat or energy released by impact), the CO₂ snow is directly converted into its gaseous state without liquefying first. This process is called sublimation.

Further characteristics:

- CO₂ snow particles contain no water.
- Their temperature is -78 °C.
- Carbon dioxide is considered non-toxic. However, exposure limits must be observed. Please consult your local BOC subsidiary for support.
- It usually behaves like an inert substance. This means that there is no chemical reaction with its environment.
- It is also non-flammable.

Perfect preparation with CRYOCLEAN®snow.
Surface cleaning as lacquering pretreatment.





Thanks to varying blasting geometries, it is possible to clean large and also very small surfaces, either completely or partially, and coat them afterwards.

In order to meet ever increasing quality demands on lacquered surfaces, manufacturers rely more and more on an optimal surface pretreatment. With CRYOCLEAN®snow, they can now profit from an extremely reliable and effective process.

There are one-step and multiple-step pretreatment processes. In one-step pretreatment processes, the surface is cleaned with CRYOCLEAN®snow and is lacquered directly

afterwards. In multiple-step pretreatment processes, mostly of plastics, the surface is initially cleaned with CRYOCLEAN®snow, then treated with deionised air and subsequently, before lacquering, the surface energy is increased.

For lacquering with UV lacquers, it is advisable to treat the surface with CRYOCLEAN®snow and dry the lacquers under an inert atmosphere of CO₂ with our inert gas technology.

Among the many benefits of surface cleaning with CRYOCLEAN®snow, the possibility of dry cleaning is the most notable. As the CO₂ is dry and does not leave any cleaning agent residues, time and energy-consuming drying processes are not necessary after cleaning. This allows a very compact design of the lacquering system and results in reduced operating costs. Furthermore, complete units can be pretreated and lacquered in the assembled state.

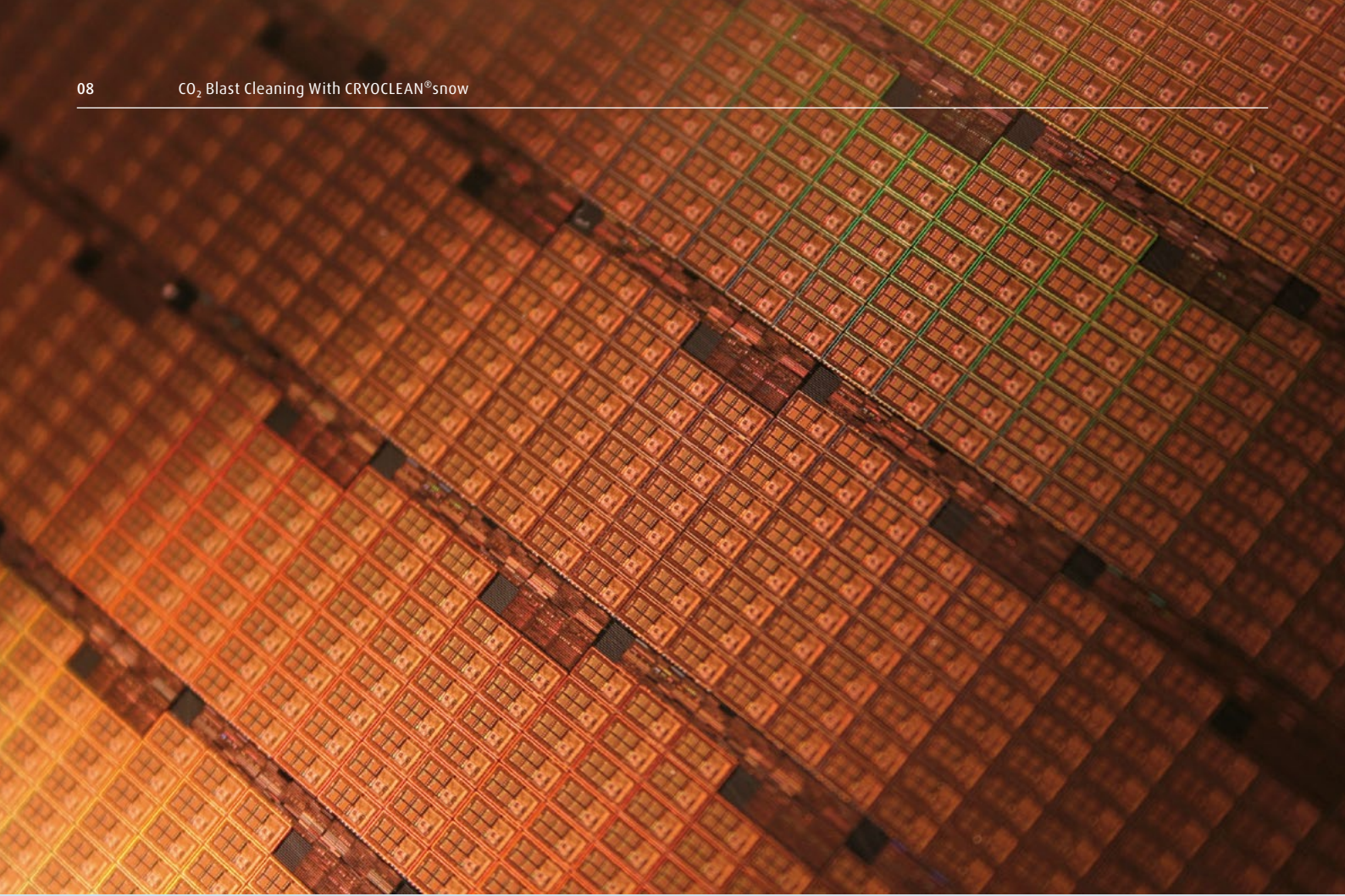

Successful utilisation. Further possible applications of CRYOCLEAN[®]snow.

Pretreatment in joining processes

Joining processes, such as welding, brazing and gluing, require that the surface is only pretreated in the areas of the joint.

With CO₂ snow blasting, we have succeeded in developing a process that exactly meets this requirement and limits the cleaning power to the surfaces to be joined. CRYOCLEAN®snow is equally successful in the removal of smoke and welding residues.

Mould cleaning

The cleaning of moulds in foundries with CO₂ blasting is considered standard by now. In recent years, CO₂ snow blasting has been increasingly established in the automated cleaning process. In polyurethane foaming, the CO₂ needed for the automated mould cleaning with CRYOCLEAN®snow can also be utilised as a foaming agent and as a carrier medium for the application of the mould release agent.



You can rely on our experience. Supply and delivery.

One needs experience to find optimal supply solutions for a variety of applications. Our application engineers provide this experience when they analyse the requirements of the customer and develop solutions which are exactly adapted to the respective manufacturing process and thus ensure process safety. With our services SECCURA® automatic gas supply and ACCURA® gas management, the gas supply can be monitored and controlled without any troubles. For this reason, supply shortage has become a problem of the past.



SECCURA® automatic gas supply

SECCURA® is the automatic gas supply on the basis of remote tank monitoring. By means of electronic sensors and a computer on the tank, pressure and fill level are continuously determined, recorded and transferred electronically to the BOC Distribution Center. The dispatchers at BOC immediately arrange the supply of the tank as soon as the fill level falls below a specified limit.



ACCURA® gas management

ACCURA® is a service for the monitoring and controlling of the liquid gas demand on the basis of internet technology. Particularly in combination with SECCURA® automatic gas supply, customers can easily track their latest tank levels, as well as user and delivery order data per tank and site, online at any time. Comprehensive statistics, comparisons between consumption periods, and regular reports via e-mail support the analysis and planning of the gas demand.

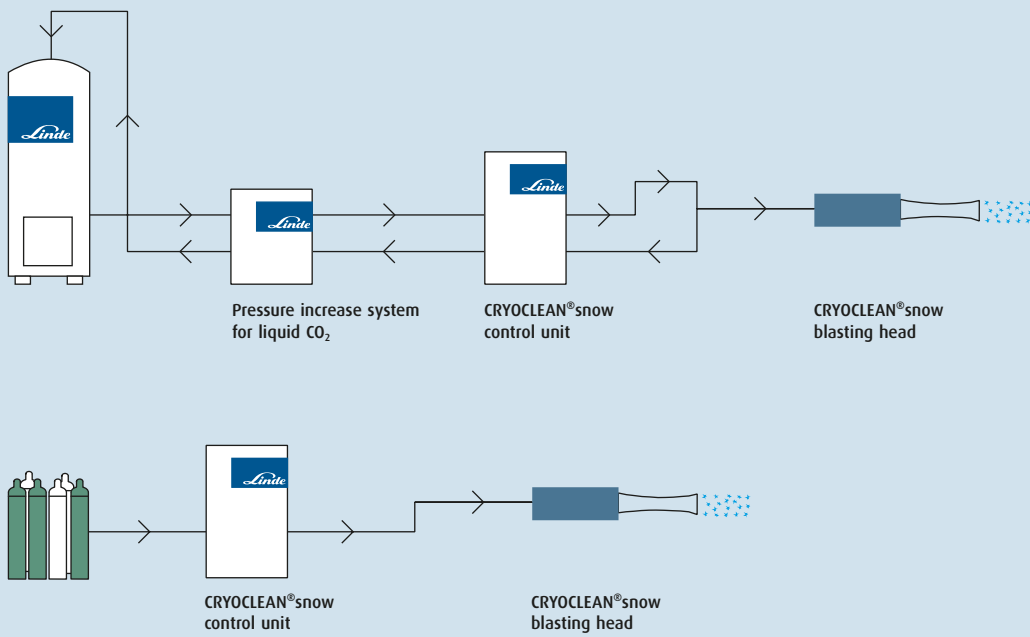

System assembly CRYOCLEAN®snow

BOC – turning ideas into solutions

BOC is a member of The Linde Group, the leading global gases and engineering company. BOC is the UK's largest provider of industrial, specialist and medical gases, as well as related products and services. As a leader in the application of technology, we are constantly looking for new ways to provide our customers with high quality products and innovative solutions.

At BOC we help our customers to create added value, clearly discernible competitive advantage and hence greater profitability. To achieve this we have a comprehensive range of products and services, and technical support which can be customised to meet the individual requirements of our clients.

To keep ahead of the competition in today's market, you need a partner for whom quality, service, process and productivity optimisation are an integral part of customer support. We are there for you and with you, helping to build your success.

BOC's reputation has been forged through partnerships – with customers, with relevant regulatory authorities and with key suppliers. In this way, we deliver comprehensive and consistent benefits to you.

BOC – world-leading knowledge and resources adapted to local requirements.

For enquiries please contact:

BOC Limited

Customer Service Centre,
Priestley Road, Worsley,
Manchester M28 2UT

Tel 0800 111 333
Fax 0800 111 555

Email custserv@boc.com

BOC Ireland

PO Box 201,
Bluebell, Dublin 12,
Republic of Ireland

Tel 1800 355 255
Fax (0)1 409 1801

Email irelandsales@boc.com

BOC Limited

Customer Service Centre, Priestley Road, Worsley, Manchester M28 2UT, United Kingdom
Tel 0800 111 333, Fax 0800 111 555, boconline.co.uk

BOC Limited registered office, Forge, 43 Church Street West, Woking, Surrey GU21 6HT, England. Company number 337663 – English Register. Authorised and regulated by the Financial Conduct Authority, register number 715528. BOC is a company name used by Linde plc and its affiliates. The BOC logo, the BOC word, ACCURA®, CRYOCLEAN®, ECO-SNOW®, ICEBITZZ® and SECCURA® are trademarks or registered trademarks of Linde plc or its affiliates. Copyright © 2018–2022. BOC Ltd.