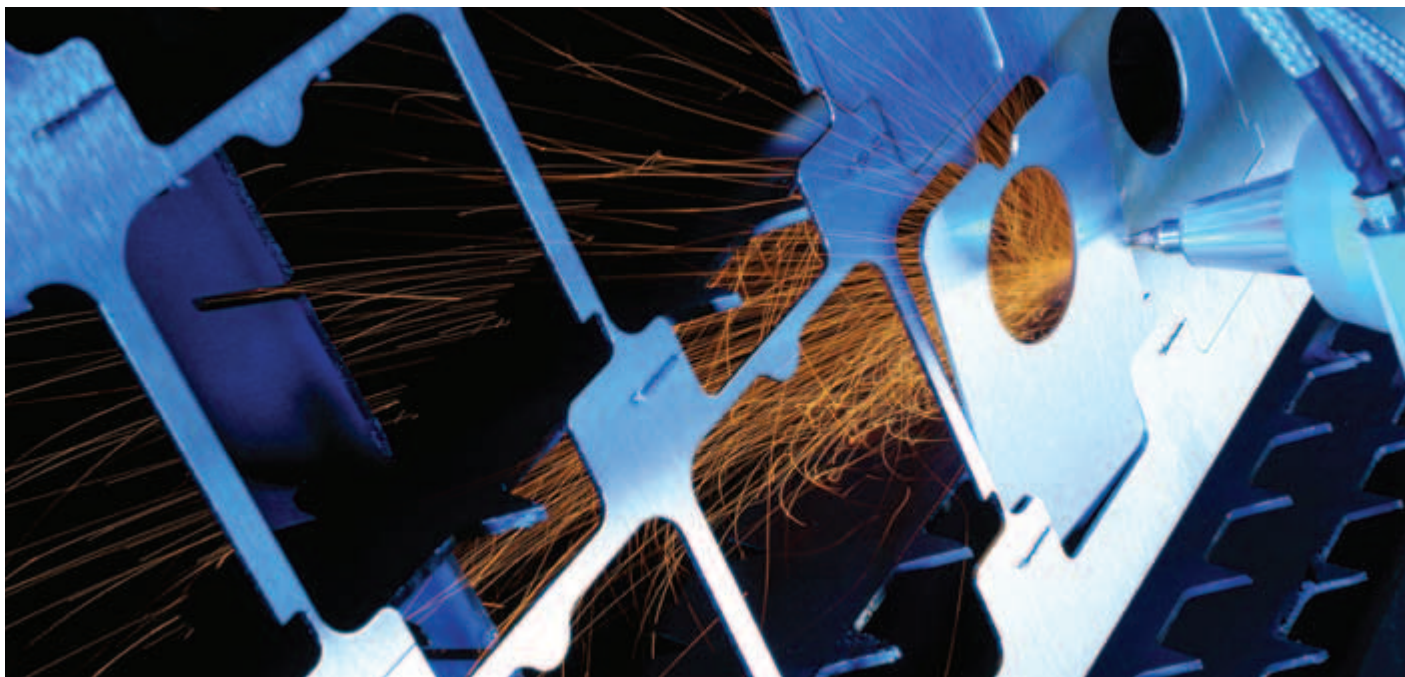


# Laser basics. LASERLINE<sup>®</sup> Technical.

# Contents.

- 03 Introduction**
- 04 The term “Laser”**
- 05 Properties of laser radiation**
  - 05 Monochromaticity, coherence, and divergence
  - 05 Intensity distribution and mode order
  - 06 Quality feature of laser radiation
  - 06 The K and M<sup>2</sup> quality parameters
- 07 Generation of the laser beam**
- 08 Elements of a laser beam source**
  - 08 The laser-active medium
  - 08 The resonator
  - 08 Excitation
  - 09 Cooling
  - 09 Other elements
- 10 Operational conditions of a laser**
- 11 Industrial laser beam sources**
  - 12 The CO<sub>2</sub> laser
  - 14 The YAG laser
  - 15 The fibre laser
  - 15 The excimer laser
- 16 Beam guidance and shaping**
  - 16 The beam guidance system
  - 17 Fibre optics
  - 18 Processing head
  - 19 Materials handling
- 20 Laser processing of materials**
  - 20 Laser cutting
  - 22 Laser welding
  - 22 Surface treatment with lasers
- 23 Laser processing in competition with other technologies**
  - 23 Thermal cutting and mechanical cutting
  - 24 Welding
- 25 Notes on safety**
  - 25 Laser radiation
  - 25 Electrical power supply
  - 25 Cutting and welding emissions
  - 26 Gases and gas supply
- 27 Literature**

## Introduction.



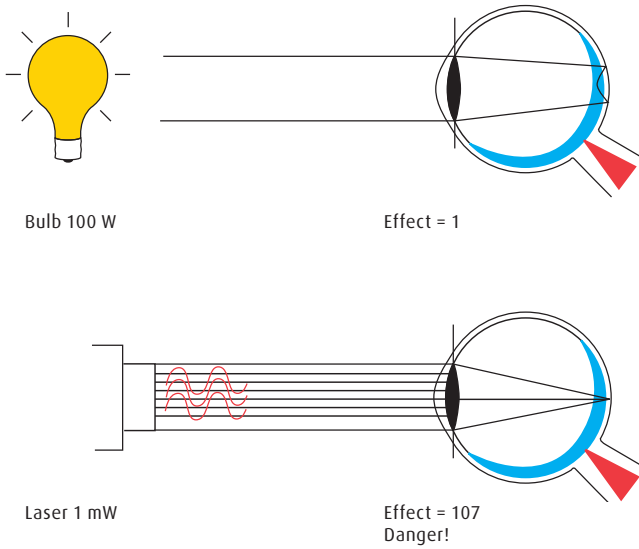
It is impossible to imagine living without the use of lasers. Everybody benefits from laser technology every day, be it whilst on the phone, watching TV, or surfing on the Internet, where data is transferred via laser diodes and fibre optics, be it while shopping (product labels and scanner cash registers) or while driving. We could mention laser cutting, laser welding, and laser marking in vehicle production, or laser diodes as indicators, in headlights, in traffic lights, etc. Most of the laser (diodes) used are not very powerful and consequently unsuitable for materials processing.

The structure of these lasers and how they work do not, however, differ fundamentally from powerful lasers that are used for laser cutting, laser welding, and similar tasks in many areas of industrial production. Here, the laser beam is powerful enough to spontaneously melt and even vaporise the workpiece. Laser cutting is the most frequently used laser method for thermal cutting of steels, stainless steels, aluminium, copper, etc., but also for cutting non-metals such as plastics, wood, paper, textiles, and so on. Laser technology has not only replaced existing methods in welding, it has also opened up entirely new applications, such as welding of tailored blanks. Today, it also plays an important role in surface treatment, hardening, and labelling, as well as in drilling.

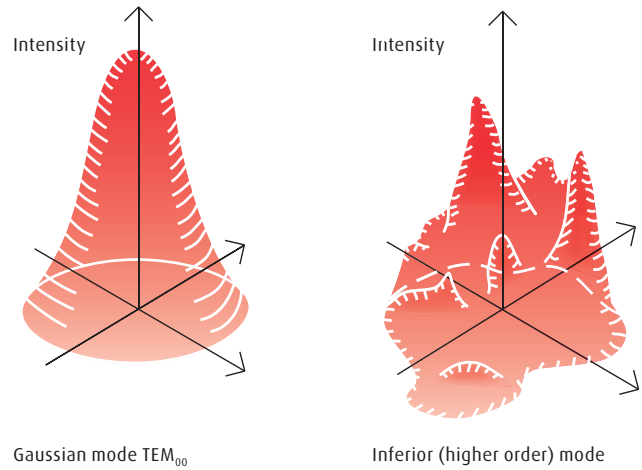
This brochure aims to provide an introduction to laser technology. It will provide a simplified presentation of essential physical basic principles of the beam generation process and explain the structure of lasers and how they work. Technical gases are often used in practical laser application, be it as laser gases for generating laser radiation or as process gases that support the cutting process or welding process. The specification of type and purity of these gases can significantly influence the economic efficiency of laser facilities and should meet the demands placed on quality in the respective application. This issue and other issues of LASERLINE® Technical (see Chapter 12) aim to provide assistance with reference to this subject.

# The term "Laser".

**Fig 1: Non-directional light from a light bulb and directional, monochromatic, coherent laser light**

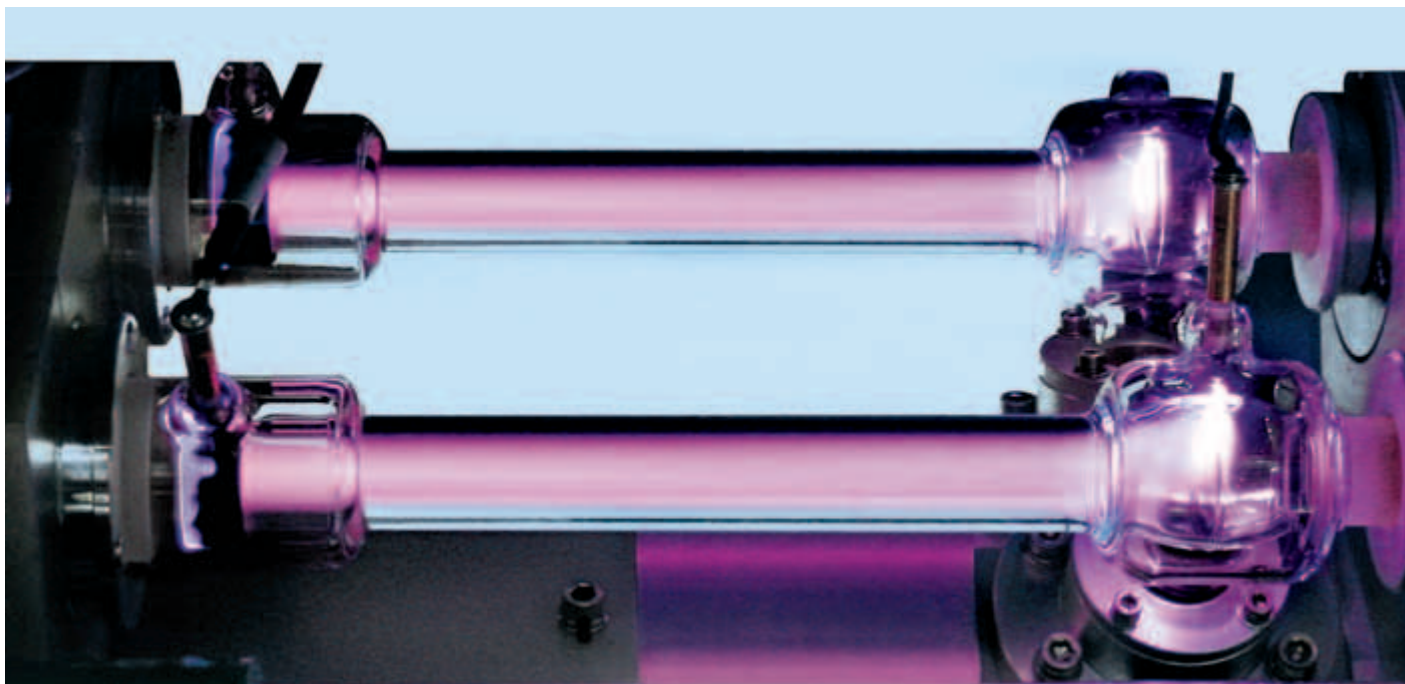


**Fig 2: Distribution of intensity in the laser beam**



The term "Laser" is an acronym for the description of the laser process: Light Amplification by Stimulated Emission of Radiation. In other words: A beam of light is amplified by supplying a laser-active medium with energy, exciting it and then using already existing radiation to stimulate it to emit radiation itself. This radiation is not always in the visible range, and particularly the laser beams used in materials processing radiate in the infrared and ultraviolet ranges, so that they are not visible.

## Properties of laser radiation.



A laser generates light with particular properties that spreads out in the form of an electromagnetic wave. Laser light's special properties are its monochromaticity, coherence, and the low divergence.

The energy of the radiation depends on frequency in accordance with the equation  $E = h \cdot \nu$ , which describes the energy of the individual light photons. Therefore, we have an electromagnetic wave that so to say effectively carries energy in small portions or pellets (photons). This simplified concept can serve as a satisfactory explanation for numerous phenomena, such as the photoelectric effect, for example. Other phenomena like interference tend to be better described by the pure wave character of light.

### Monochromaticity, coherence, and divergence

Both natural light and light from a light bulb are composed of radiation of many different wavelengths, a phenomenon that becomes vivid in a rainbow. Light from a light bulb spreads out in all directions, so that it is non-directional, see Fig. 1. As a result, the intensity of light is very low at a specific point. Laser light is only composed of radiation of a single wavelength (monochromaticity), all of the waves have the same phase position (coherence) and they spread out almost in parallel (low divergence). Therefore, intensity in the laser beam is very high at long distances as well. Laser beams can consequently be bundled in a small focal spot of often less than 0.5mm (0.02 in.) diameter at a long distance from the source of radiation, for example 20 m (60 ft), so that a concentration of energy can be obtained that is sufficient for melting and vaporising steel.

### Intensity distribution and mode order

Distribution of beam power across the beam (beam intensity) depends on numerous factors such as the structure of the resonator, the optics and apertures, etc. used and is described by the so-called mode order.

Ideal distribution of energy would be Gaussian-shaped with high intensity at the centre of the beam and a decrease in intensity toward the edges, see Fig. 2. This mode order or distribution of intensity is referred to as  $TEM_{00}$  (Transversal Electromagnetic Mode of the order 0) and called the basic mode or Gaussian mode. This mode would be particularly suitable in laser cutting due to the fact that the mode is radial symmetric to its centre and cutting results will be independent of the cutting direction. Nevertheless, a different distribution of energy in the beam may be advantageous in other applications.

## Quality feature of laser radiation

As just described, the ideal distribution of energy in the beam would be Gaussian when the laser radiation oscillates in the basic mode  $TEM_{00}$ . However, the mode is subject to time-related changes and only serves as one criterion for the quality of the beam.

The divergence of the laser radiation is another criterion, even though divergence is only very slight, it is present all the time. Therefore, as the distance from the laser increases the laser beam widens independently of construction and design. This is why telescopes are often inserted in the beam path in processing systems with flying optics. They compensate for the divergence and produce uniform beam parameters along the beam propagation or beam path thereby enabling constant processing results.

The beam parameter product as a product of beam radius and beam divergence forms the quality feature for beam quality that takes account of both the divergence of the radiation and the diameter of the beam. Generally, the greater the laser's power, the greater the beam parameter product is and, accordingly, the poorer the beam quality will be. Typical values for cutting lasers in metal processing range from 3 to 30mm · mrad.

## The K and $M^2$ quality parameters

In laser cutting, the grade of laser radiation has a direct influence on the achievable quality of cut and productivity. Different cutting lasers can be compared relatively simply on the basis of the K or  $M^2$  quality parameters ( $M^2$  is common in the USA and UK,  $K = 1/M^2$ ). K describes the ability to focus the laser radiation in a small focal spot in accordance with

$$K = \frac{4 \lambda}{\pi} \cdot \frac{f}{D} \cdot \frac{1}{d_f}$$

With  $\lambda$  being the wavelength of the laser light,  $\pi$  a constant,  $f$  the focal length of the lens,  $D$  the diameter of the raw beam, and  $d_f$  the diameter of the focus, see Fig. 3. Accordingly, K is essentially determined by  $D$  and  $d_f$ , i.e. the diameter of the unfocused laser beam and that of the focused beam. Therefore, the divergence of the beam is also covered.

$K = 1$  for an ideal Gaussian beam and  
 $K < 1$  for real laser radiation.

Multi-kW  $CO_2$  lasers for laser cutting usually have a K factor of 0.5–0.8 which is equal to  $M = 1.25 - 2$ . In this power range, the beam quality of Nd:YAG lasers is usually inferior to that of  $CO_2$  lasers.

# Generation of the laser beam.

Fig. 3: Focusing ability of laser radiation

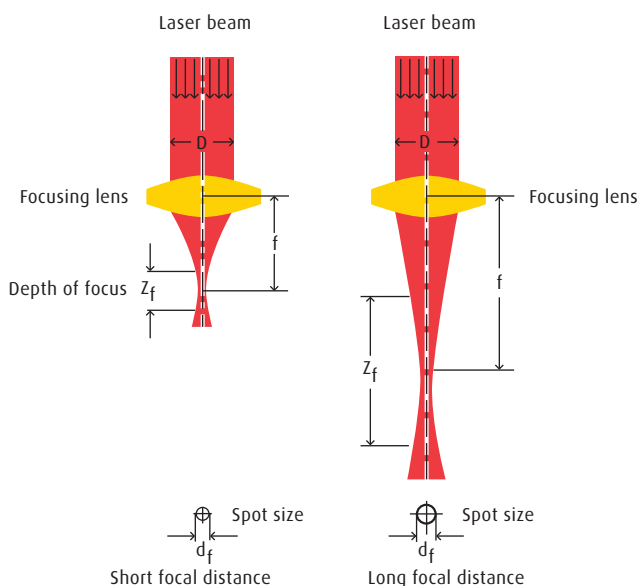
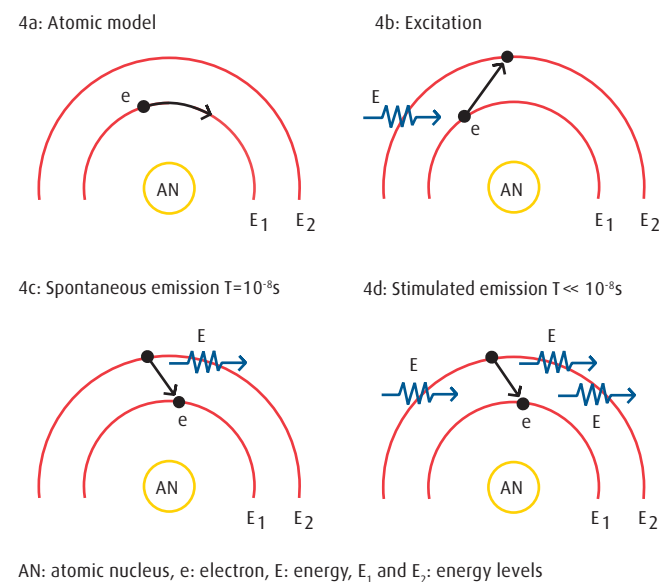


Fig. 4: Atomic model, excitation, spontaneous emission, stimulated emission



In order to generate a laser beam, you need a laser-active medium, which may be gaseous, solid or liquid, which is stimulated by some kind of energy such as electrical discharge, high-frequency or radiation.

This medium consists of atoms with a nucleus and surrounding electrons, see Fig. 4a. If the medium is supplied with energy (E), its atoms or molecules take on a state of higher energy; they are "excited." In the process, its electrons are transferred to a higher level of energy ( $E_1 \rightarrow E_2$ ), see Fig. 4b. Molecules start to oscillate as a result of the energy input. However, this so-called excited state is not stable, and the excited particles always want to return to their own original position (lowest level of energy). They do so after characteristic dwell times in  $E_2$  ranging from  $10^{-7} - 10^{-8}$  s and emit the stored energy in the form of heat or impulse energy or in the form of light again ( $E_2 \rightarrow E_1$ ), see Fig. 4c. This process is called spontaneous emission.

Einstein was the first person to identify the basic prerequisite for lasers to function: Emission of stored energy can be induced or stimulated in a targeted fashion before the characteristic dwell time is reached. It may sound like a paradox, but the way to achieve this is to hit atoms or molecules that have already been excited with additional energy e.g. in the form of radiation. Instead of storing the additional energy the atoms or molecules will release their energy and fall back to the lowest energy level. The radiation released during this stimulated emission travels in the direction of the incoming energy, see Fig. 4d. In contrast to spontaneous emission it is not released in a random direction. Therefore the process of stimulated emission amplifies the radiation coming in: The direction of the emitted radiation is identical to that of the incoming radiation. If there are enough stimulated atoms/molecules and if reinforcements are ensured by a supply of energy, the stimulated emission can lead to amplification of the radiation with a snowball effect. The radiation produced is characterised by uniform wavelength, uniform phase position and uniform direction of dispersion.

# Elements of a laser beam source.

The following components form parts of a laser beam source: a laser-active medium, a resonator, excitation and cooling.

## The laser-active medium

Media emit the stored energy again in diverse forms. Laser-active media are materials that send out part of the emission energy in the form of laser radiation. When processing materials using laser radiation, these media are predominantly carbon dioxide as part of CO<sub>2</sub> gas lasers and a fluorine/halogen or chlorine/halogen mixture in excimer gas lasers. In solid-state lasers, the laser-active medium is a doped crystal such as an yttrium-aluminium-garnet (crystal) enriched with neodymium or, if applicable, with ytterbium in Nd:YAG and Yt:YAG lasers. Diode lasers consist of numerous laser diodes that are excited by electrical energy in a semiconductor. The rather new fibre laser is another example of a solid-state laser. In this laser, an element from the "rare earths" group, e.g. ytterbium, is embedded in the centre of an optical fibre as a laser-active medium.

We should not forget the helium-neon (HeNe) laser, a gas laser with only low power. However, in contrast to the other lasers mentioned, it radiates in the visible spectrum and is useful in a laser machine to position material relative to the beam. Laser diodes have replaced helium-neon lasers in modern laser systems. The high-power laser beam is generally blocked away when the set-up laser beam becomes visible.

## The resonator

Components required to generate laser radiation are contained in the resonator. In the simplest solution, the resonator is built from two mirrors between which the laser radiation is reflected back and forth, see Fig. 5. One of the mirrors is fully reflecting, while the other one, via which the usable laser radiation is outcoupled (leaked), is partially transmissive.

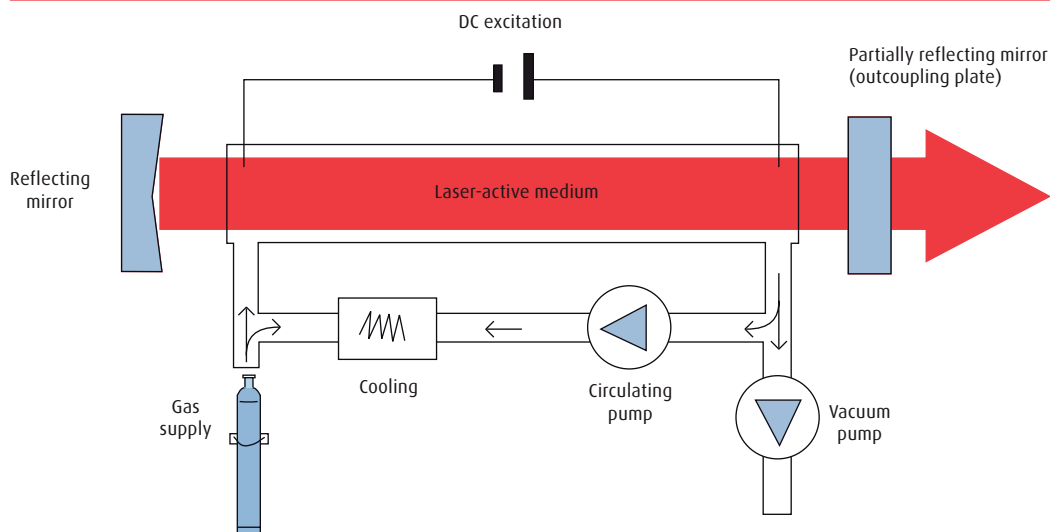
The geometry of the mirrors, diameter, and length of the resonator must match in order to achieve high beam performance along with good beam quality. If beam performance is high and the resonator is correspondingly long, the resonator will be folded several times e.g. in the shape of a triangle or a square.

## Excitation

Diverse forms of energy such as electrical energy, light photons, chemical reactions, and so on, are used to stimulate the laser-active medium. In CO<sub>2</sub> gas lasers, the energy is fed directly into the laser-active medium in the form of direct current using electrodes or transferred capacitively through the resonator wall by means of electromagnetic fields.

When DC (direct current) excitation is used, gas is discharged if direct current of several kilovolts is applied between the electrodes, see Fig. 5. The electrodes are subjected to a strong load in this process which can cause erosion (electrode erosion). The ability to pulse is limited to a frequency of approx. 1 kilohertz, but the super-pulse mode is possible (Refer to Operational conditions of a laser, page 10, for details).

**Fig. 5: Principle structure of a resonator (example: CO<sub>2</sub> laser)**



High-frequency excitation, i.e. RF (= radio frequency) excitation, in the range of a few megahertz takes place through electromagnetic fields that are produced by electrodes placed outside of the resonator. While the atoms and molecules inside the laser-active medium try to follow the changing polarity of the field, they eventually heat up, collide with each other and eventually get excited. This set-up avoids electrode erosion and permits good pulsing ability, but is associated with a higher investment cost.

When using solid-state lasers, excitation is realised by the use of lamps or laser diodes or, as applicable, via electrical energy in diode lasers.

### Cooling

Since only a minor portion of the energy used is actually converted into laser radiation, it is important to cool the laser medium effectively. Most of the energy is unfortunately converted to heat and must be taken out of the medium as heat interferes with the generation of laser radiation. Circulation of the laser gas, which is passed through a heat exchanger, is used to cool the laser-active medium in CO<sub>2</sub> lasers, see Fig. 5. Heat can also be removed through the resonator wall without having the laser gas circulate (diffusion cooling), however, the energy that can be drawn off this way is limited.

In Nd:YAG lasers, the laser crystal can only be cooled from the outside, which also restricts heat removal and limits maximum laser performance. By contrast, the Yt:YAG crystal is mounted directly on a heat exchanger in a Disk Laser, to the effect that higher laser performances and better beam quality compared to Nd:YAG lasers can be achieved as a result of direct cooling.

The diodes of the diode laser are also mounted directly on a heat exchanger, which ensures good cooling.

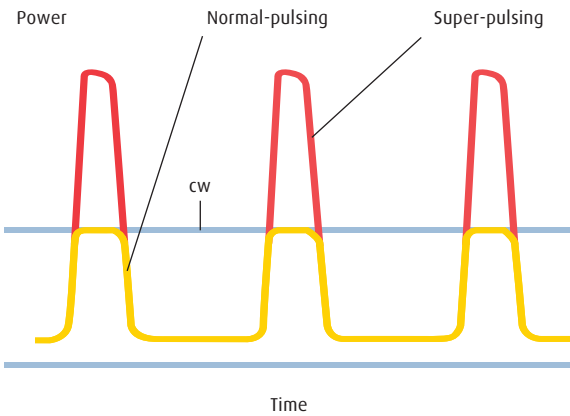
A fibre laser is comprised of numerous fibres that only convert relatively low power individually. In addition, the efficiency of this laser is close to 50%, so that there is less overall thermal waste than in other systems. Accordingly, these systems can usually operate up to laser powers of some kW without water cooling.

### Other elements

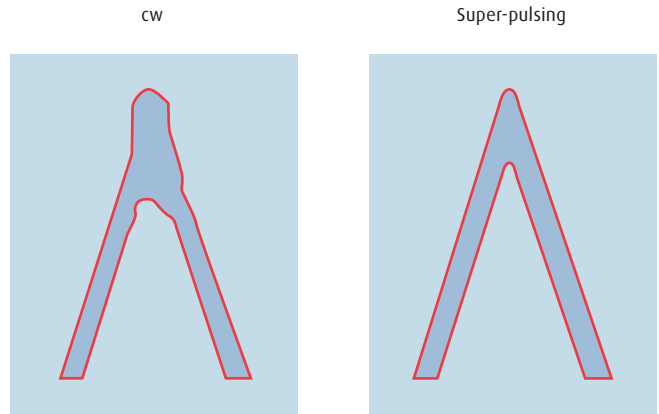
Although other elements such as a control are needed to operate the laser, we will only concentrate on the components that are a minimum requirement for beam generation.

# Operational conditions of a laser.

**Fig. 6: Cw operation, pulsing and super-pulsing**



**Fig. 7: Advantages of pulsing when cutting sharp corners**



Lasers operate continuously or pulsed. In continuous or cw operation (continuous wave), a constant level of laser beam power is provided.

The level of power output is adjustable. In actual practice, this means that a laser beam that reflects back and forth between the resonator mirrors is generated continuously in the resonator. Part of this radiation exits the resonator continuously through the output window or output coupler.

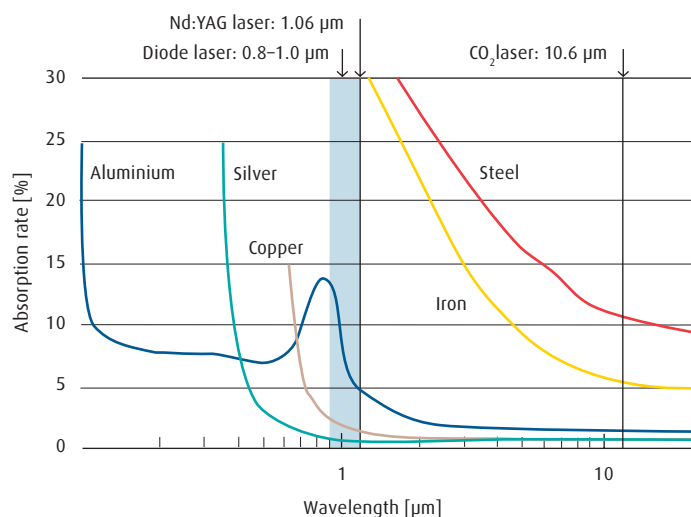
During breaks the resonator is either turned off or preferably operated at low power, because the optical elements in the laser can handle a low constant thermal load easier than rapid cooling and heating cycles. The generated low power beam is cooled away. When a workpiece is processed, power is increased accordingly, and the outcoupled beam, which is now high-powered, is used for operation.

In normal-pulse mode, the laser is basically switched on and off very quickly, see Fig 6. Common pulse frequencies range from 100 Hz to 10 kHz. The pulsing makes it possible to reduce the average energy input into the workpiece. For example, during cutting, this enables the energy to be adjusted to the feed rate and the shape of contour, so that sharp corners and filigree structures will not overheat and burn uncontrollably, see Fig. 7. Pulsing is often used for piercing as well.

In normal-pulsing, the peak pulse power approximately corresponds to the laser's cw power. When super-pulsing is used, the peak power can be a multiple of cw power, see Fig. 6, if the laser is suited for super-pulse mode. Super-pulsing can be achieved by using special resonators that can be operated in an oscillator-amplifier configuration. Here, a high-grade but low-power laser beam is generated in an oscillator part. It is amplified many times over by the excited medium in the amplifier. Super-pulsing can further reduce the thermal load on the workpiece. Superb cutting quality can be achieved in the pulsing mode and particularly in the super-pulsing mode, although the attainable cutting speed is very low due to fact that the average power is very low.

# Industrial laser beam sources.

**Fig. 8: Absorption rate for laser radiation in cold metal**



The productivity of a laser beam process is essentially determined by laser beam power, although the quality of the laser beam provided is also important for production quality especially in applications such as high precision cutting and drilling. The relationship of the absorption rate of the workpiece for the laser radiation used and its wavelength forms another aspect to be considered.

The absorption of CO<sub>2</sub> laser radiation by cold metallic materials is relatively poor, see Fig. 8. Which means in return that a large portion of the initial laser radiation is reflected (refer to notes on safety, page 25).

By comparison, the radiation of diode lasers and solid-state lasers is absorbed better by cold metal. However, absorption rate improves noticeably as the temperature increases all the way to almost complete absorption of the entire laser beam power at melting temperatures of the workpiece.

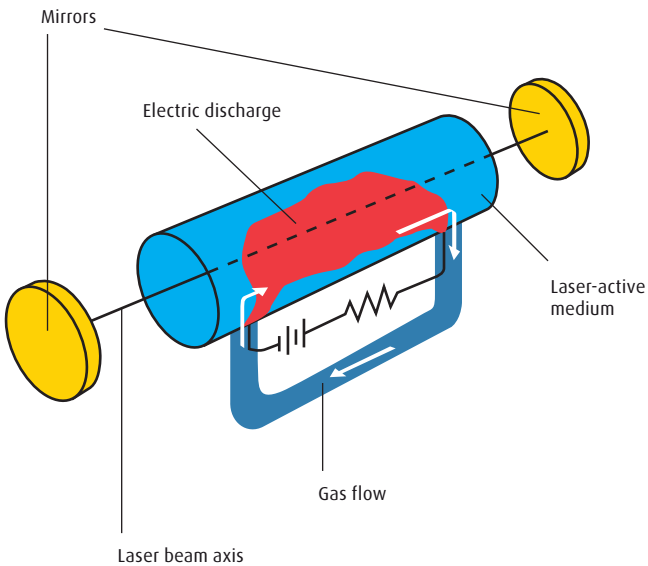
Absorption of the laser radiation in different materials correlates with the wavelength of the laser light. Accordingly, different materials can be processed well by diverse lasers. For example, CO<sub>2</sub> laser radiation is absorbed relatively well by steels, plastics, and plywood and moderately well by light metals. Nd:YAG laser radiation is absorbed well by steels, well by non-ferrous metals, but barely absorbed by plastics or plywood, see Table 1.

**Table 1: Cutting suitability of different materials**

Material	Wavelength (micrometer)	
	Nd:YAG laser: 1.06	CO <sub>2</sub> laser: 10.6
Construction steel	highly	highly
Stainless steel	highly	highly
Aluminium	well	well
Copper	well	difficult
Gold	well	not possible
Titanium	well	well
Ceramics	difficult	well
Perspex	meanly	highly
Polyethylene	meanly	highly
Polycarbonate	meanly	well
Plywood	meanly	highly

# Industrial laser beam sources.

Fig. 9: Fast axial gas flow CO<sub>2</sub> laser



There are many types of lasers with lots of different applications, however most of them only deliver very low laser beam power and so are not suitable for materials processing. Lasers for industrial applications include gas lasers such as CO<sub>2</sub> or excimer, and solid state lasers such as YAG or fibre.

## The CO<sub>2</sub> laser

As the name implies, carbon dioxide is the laser-active component in the CO<sub>2</sub> laser's gas mixture, which also contains helium and nitrogen as additional main components. Besides these main components, a few CO<sub>2</sub> lasers require admixing of oxygen, hydrogen, carbon monoxide, and/or xenon, which additionally support the physical and chemical processes in beam generation. The laser gases must meet stringent purity requirements. Even small amounts of contamination, such as moisture and hydrocarbon compounds, interfere with beam generation and reduce power and lead to inferior beam quality.

The laser gas mixture is positioned in glass tubes between the resonator mirrors. The glass tubes are connected to a pipe system which is used to circulate the laser gas mixture from the resonator into the heat exchanger and back into the resonator, see Fig. 5. The laser gas can flow in different ways: in the direction of the laser beam (axial gas flow) or perpendicular to the same (transverse gas flow), at a high gas speed or a low speed. Every system has specific advantages and disadvantages. The laser gas tube can also have a flat, elongated shape, with its walls serving as heat exchangers and thereby making circulation of the laser gas mixture obsolete (diffusion-cooled laser).

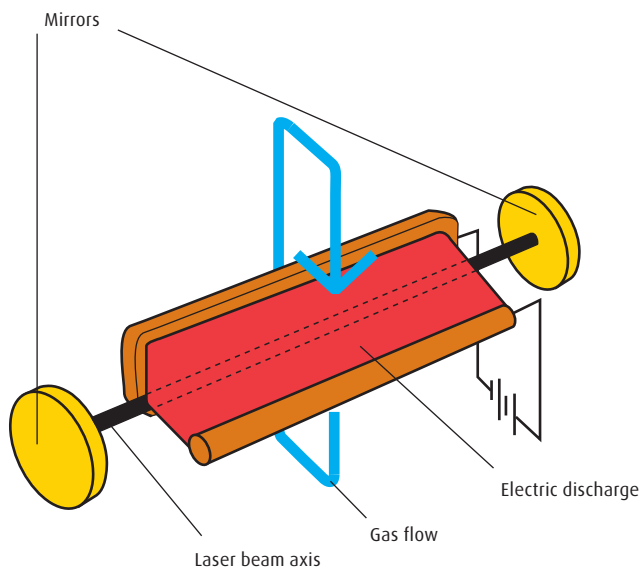
Fresh laser gas mixture is continuously fed into the systems in order to compensate for losses, change in composition and increasing levels of contaminations. Beyond that, the resonator is flooded with nitrogen upon shut-down or purged with nitrogen upon restart in various lasers.

## Axial gas flow CO<sub>2</sub> lasers

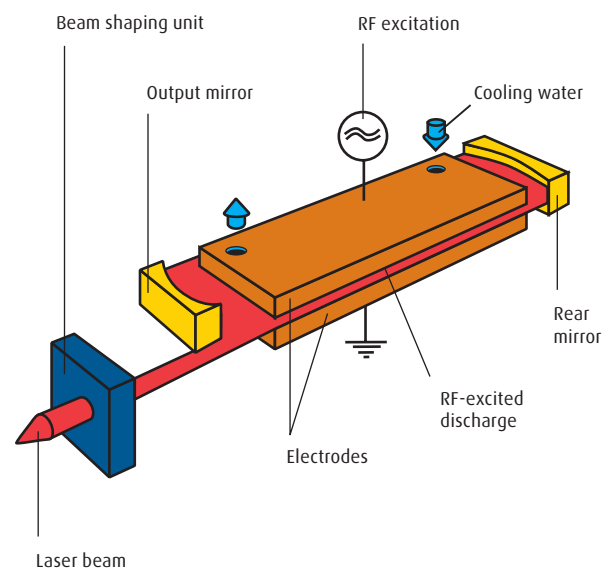
In this type of laser, the laser mixture flows in the direction of the laser beam in the resonator, see Fig. 9. Slow-flow lasers operate with a gas flow rate of approx. 5 m/s (16 ft/s) and are usually excited by a direct current. Cooling is normally accomplished via the resonator wall, to the effect that no more than a few 100 W of laser beam power per metre of resonator length can be generated. Accordingly, high laser beam powers require longer resonators, and the resonators are folded in order to obtain a compact structure. The slow-flow laser provides high beam quality up to laser beam powers in the range of 1 kW. Precision cutting and precision drilling are examples of areas of application for this laser.

Heat removal could be improved significantly in the fast-flow laser, where the laser gas mixture is driven by Roots pumps or turbines and circulated at over 500 m/s (1,640 ft/s) and cooled by a heat exchanger, see Fig.s 9 and 5. This makes it possible to build very compact lasers with a high output of more than 20 kW. Excitation is effected by means of direct current or high frequency. Most of the lasers used in materials processing function according to this principle.

**Fig. 10: Transverse gas flow CO<sub>2</sub> laser**



**Fig. 11: Diffusion-cooled CO<sub>2</sub> laser**



### Transverse gas flow CO<sub>2</sub> lasers

Even greater cooling performance can be achieved by exchanging the laser gas mixture perpendicular to the laser beam axis, as is done in the case of the transverse gas flow laser, see Fig. 10. Circulation is effected by a blower, and the laser gas mixture is cooled by a heat exchanger. The large resonator volume and efficient cooling makes it possible to achieve high laser beam powers in excess of 50 kW. This type of laser is normally excited by direct current. Based on the perpendicular temperature gradient the beam quality is inferior to that of axial gas flow lasers and insufficient for laser beam cutting, but suited for welding and particularly well suited for surface treatment.

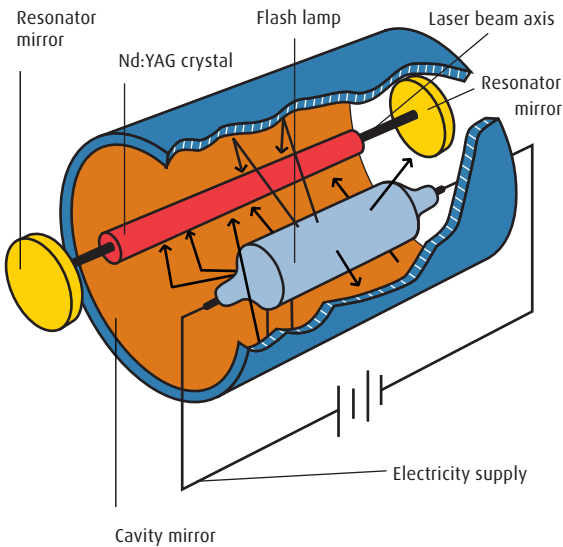
### Diffusion-cooled CO<sub>2</sub> laser

A diffusion-cooled laser is equipped with a resonator, in which the laser gas mixture is contained between two flat, water-cooled electrodes, which also act as heat-exchangers. Energy is transferred via high-frequency excitation, see Fig. 11. Gas flow in the resonator is controlled by the temperature difference only, cooling is effected convectively via the heat-exchanger plates. This laser is very compact as a result of the missing gas circulation, blower, external heat exchanger, etc. Today, laser powers of up to approx. 8 kW are achieved with a good beam quality. Recently, a new diffusion-cooled laser has been developed which uses a tubular resonator for convection cooling of the laser gas mixture.

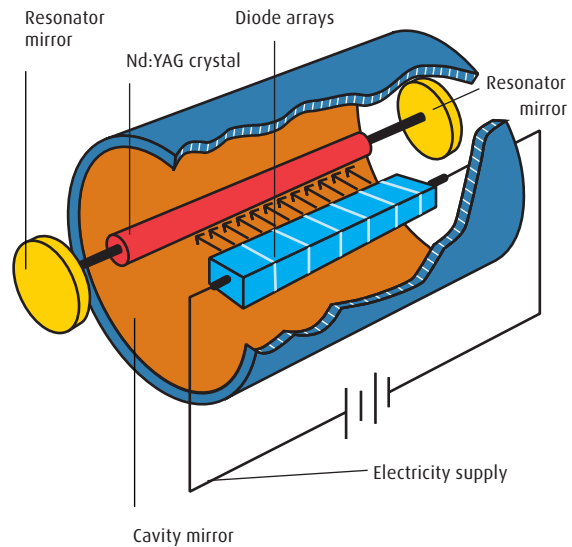
### TEA lasers

TEA stands for Transversely Excited Atmospheric pressure, and the TEA laser is also a CO<sub>2</sub> laser, although it is not operated at the low pressure associated with other CO<sub>2</sub> lasers, but rather at approx. atmospheric pressure. This laser is always operated in pulsed mode, the laser gas mixture is cooled convectively and the gas mixture is only exchanged a few times per year. It produces only a few 100 W and is primarily used for marking e.g. production data and expiration data.

**Fig. 12: Nd:YAG laser, lamp-pumped**



**Fig. 13: Nd:YAG laser, diode-pumped**



## The YAG laser

The laser-active medium of the YAG laser is an artificially grown YAG monocrystal (yttrium-aluminium garnet = yttrium-aluminium crystal) that the neodyme (Nd:YAG) or ytterbium (Yt:YAG) is embedded in. Accordingly, the YAG laser is a solid-state laser that does not require any gas in order to generate laser radiation. The crystals are excited by light energy from lamps or by radiation from laser diodes.

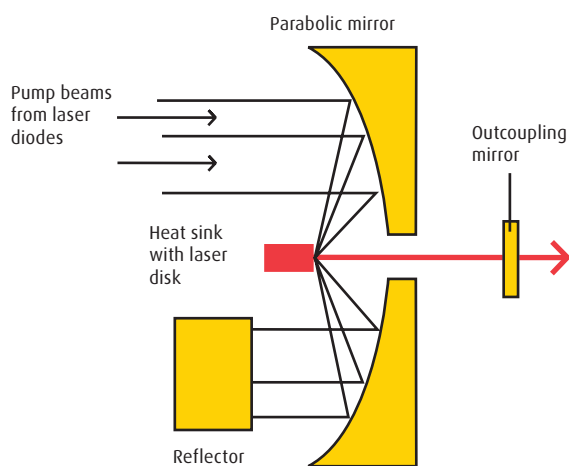
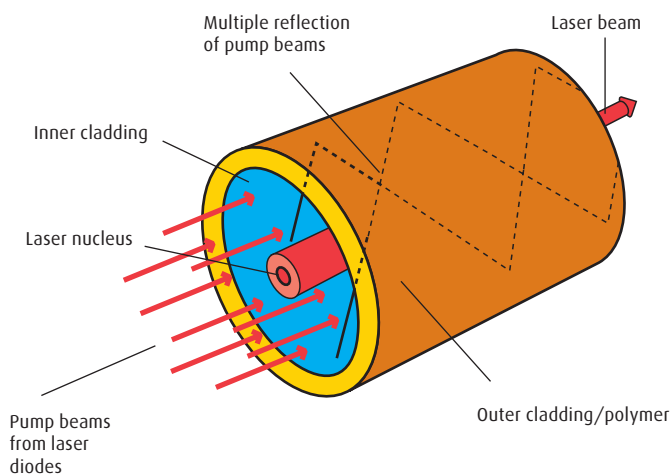
### Nd:YAG laser

The laser crystals are rod-shaped and several laser rods are placed in a resonator between two mirrors. Excitation takes place via lamps, see Fig. 12, or diode bars, see Fig. 13. Each crystal or laser rod produces laser power of approx. 500 W (lamp excitation) or 750 W (diode excitation). Heat is exchanged convectively via the housing. However, at high powers, heat tensions affecting beam quality and limiting power occur in the crystals. Lamps have a limited life of a few 100 hours to over 1,000 hours, depending on use. High laser beam powers and short periods of use contribute significantly to the aging of lamps. Diode bars contain numerous low-power laser diodes with a useful life of over 10,000 hours, which is much longer than that of lamps, but require a higher investment. The effectiveness of diode-pumped lasers is higher than that of lamp-pumped ones, and beam quality is better at high powers.

### Yt:YAG laser (disk laser)

The laser crystal has the shape of a narrow disk and is mounted on a heat exchanger. This ensures effective and even cooling and largely avoids thermal tension. A Yt:YAG crystal emits laser radiation of significantly more than 1 kW, and the laser radiation is marked by higher beam quality than Nd:YAG laser radiation. Yt:YAG lasers are pumped by diode laser radiation that is reflected many times in the direction of the crystal. Here, too, we encounter the typical resonator structure: The cooling body behind the crystal also acts as the total reflector, the outcoupling mirror lets part of the radiation through for processing, see Fig. 14. Power is increased by bundling beams from several lasers via optical elements in a common beam path.

Fig. 14: Yt:YAG laser (disk laser)

Fig. 15: Fibre laser (fibre diameter: 260  $\mu\text{m}$ )

## The fibre laser

The fibre laser consists of laser diodes and optical fibres, the core or laser nucleus of which is enriched (doped) with a laser-active medium. This "laser core" is surrounded by the "pump coat," into which the light from the laser diode is radiated from one end. Multiple reflection on the outer edge of the pump coat causes the pump light to be sent through the laser core repeatedly where the laser-active medium is located, this stimulates it and emits laser radiation.

Special plugs at the fibre ends serve as the "end mirror" of the fibre resonator. They prevent the generated laser light from radiating back into the pump diode and allow part of the laser radiation to leave the resonator. Therefore, the fibre serves as a resonator for beam generation and beam amplification and, at the same time, as a beam delivery system. Individual fibre generate laser beam powers of up to 500 W with good beam quality and high effectiveness, consequently cooling demands are less strong and water cooling often unnecessary. Higher laser beam powers are achieved by bundling the fibres together, however, this reduces beam quality.

## The excimer laser

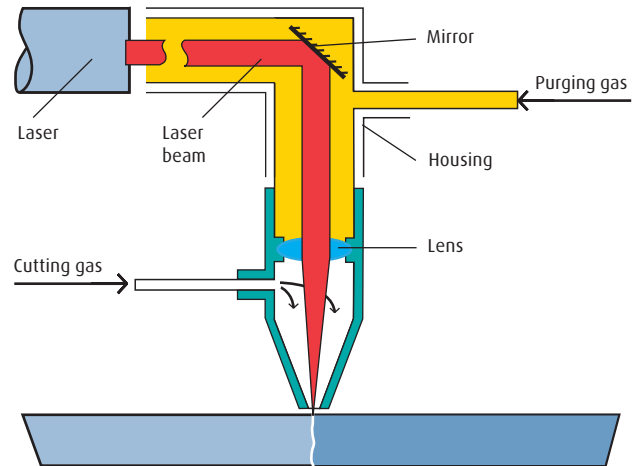
The term "excimer" is short for excited dimer (molecule with 2 atoms, excited). The excimer laser is also a gas laser, and the laser-active medium is an artificial molecule comprising of an inert gas (Ar, Kr, Xe) and a halogen (F, Cl). This molecule does not exist under "normal" conditions, but it can be formed in electric discharge and releases bond energy in the form of laser radiation when it dissociates. Fluorine and chlorine are toxic and corrosive (especially in contact with moisture) and require special measures for the arrangement of the gas supply system and handling of waste laser gas. The radiation from excimer lasers interacts with the atomic bond of the material, which are broken up and then cause removal of material (so-called "cold" removal). Excimer lasers are widely used for corrective eye surgery, but there are also individual applications in materials processing such as production of special structures on the workpiece (masking technology), cleaning and paint removal, and for the production of microchips in a process called stereolithography.

## Beam guidance and shaping.



The laser radiation produced by the laser is guided along a path of variable length to the processing site. Glass fibres, mirrors, telescopes, and other optical elements are used in this process to guide and shape the beam. A machine tool is often used to handle the workpieces.

**Fig. 16: Beam guidance system with a processing head**



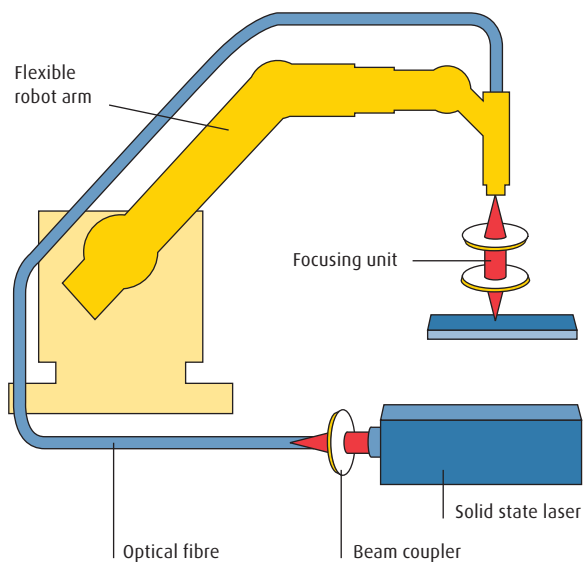
(example: laser cutting)

### The beam guidance system

The laser beam is guided from the laser to the processing site by a so-called beam guidance system (beam delivery system, beam path, beam cabinet). It utilises diverse optical elements in order to obtain the required beam properties. The laser beam and the optical elements are normally protected by protective enclosures or bellows, see Fig. 16.

The beam guidance system requires a special gas atmosphere that neither harms the mirrors nor the beam. The mirrors are normally cooled by water so that foreign gases such as moisture or hydrocarbons can condense on the mirror and alter the mirror's reflection properties. The laser beam itself can also be impaired by foreign gases, depending on the beam's intensity, changing for example its diameter ("thermal blooming" = enlarged beam diameter), so that it can damage and even ignite the mountings of the mirrors and elements of the enclosure. Argon, CO<sub>2</sub>, hydrocarbons, moisture solvents, and electronegative gases can come into play here and must be excluded, particularly when laser beam quality is high and power is greater than approx. 3 kW. In this case, high-purity nitrogen should be used as a purging gas for the beam cabinet. Compressed air can be used instead of nitrogen at low beam intensities, but they need to be free of hydrocarbons and moisture.

**Fig. 17: Fibre optics with a beam coupler and a focusing unit**

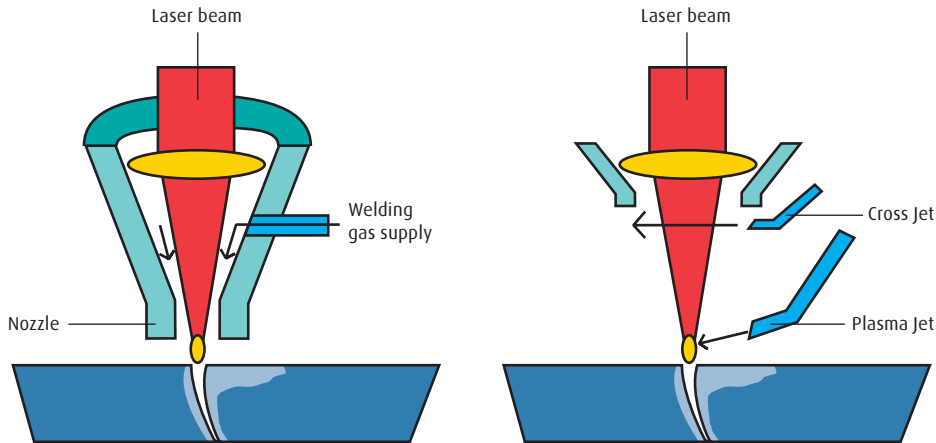


## Fibre optics

Optical fibres can also be used to guide the laser light from the laser to the process. Optical fibres are flexible glass fibres that conduct the laser light of YAG lasers or fibre lasers to a focusing head that might well be mounted on a robot, see Fig. 17. The fibres come in different diameters of less than  $100\ \mu\text{m}$  and up to approx.  $1,000\ \mu\text{m}$ . The laser beam is reflected multiple times at the walls of the fibre, thereby losing its low divergence and good focusing properties.

As a rule of thumb, a laser beam delivered through a fibre can be focused in a focal spot, whose minimum diameter equals that of the fibre. However, there is a limit to the use of increasingly fine fibres, as the laser beam produced must be coupled into the fibre first, whereby specific intensity values cannot be exceeded. The laser beam can also be distributed to a number of fibres as an interesting alternative to flexible control of the fibre by a handling system. Here, the available laser beam power is divided among individual fibres and stations, or the entire power can be assigned to one processing station in each case. Laser beams from several lasers can also be bundled in one fibre.

**Fig. 18: Coaxial gas feed and lateral gas feed via Plasma Jet supported by Cross Jet**



## Processing head

The laser beam is focused in the processing head at the end of the beam delivery or the optical fibre with the aid of mirrors or lenses. The optical elements in the head must be protected from foreign gases and particles like smoke and spatter. In many cases, process gas must be supplied as well. Different kinds of gas feed systems with coaxial action or lateral action are used in many cases.

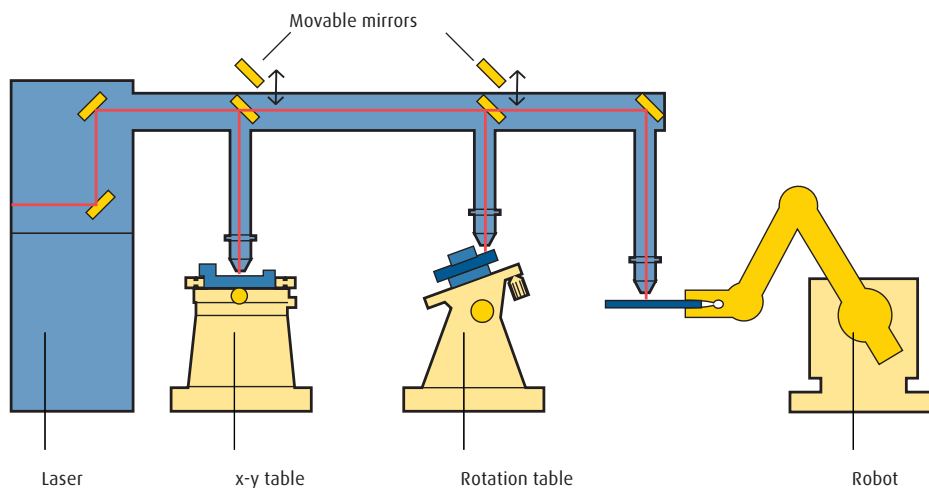
In coaxial feed, the laser beam and the gas jet follow the same path, so that the gas has intense contact with the laser beam and can be ionised, see Fig. 18. On the other hand, only one gas is needed, as it can act both as a shielding gas and a process gas; plus there is the advantage of the direction of feed being irrelevant.

In lateral feed, an additional gas nozzle is used (Plasma Jet), which guides the process gas directly into the process area without intense contact with the laser beam. An additional gas nozzle is needed to protect the optics. This is done by placing a sharp gas jet, the Cross Jet, which effectively blows fumes and spatter from the weld pool away laterally, directly beneath the optics, see Fig. 18. The Cross Jet must not interfere with the process gas atmosphere as a result of inaccurate adjustment.

Originally the Plasma Jet was designed to affect the plasma formation. It produces a strong narrow turbulent gas jet and injection of surrounding air is very likely to happen. As a result there would be limited or no shielding of weld pool at all. A better solution is a nozzle with a larger opening in the same position producing a smooth laminar gas flow.

When "almost" lateral gas feed is used, a number of holes are drilled in the body of the coaxial nozzle, and the shielding gas exits outside the centre and through several channels on the underside of the nozzle. This design overcomes the dependency on direction. A Cross Jet is normally needed additionally to ward off dust and smoke.

**Fig 19: Multi-station operation with a divided laser beam**



## Materials handling

A relative movement between the workpiece and the laser beam called feed or travel is needed in order to process a specific surface. This can be done by hand if the workpiece is very small e.g. in the jewellery industry, but large workpieces are often fed on an x-y table under the laser processing head, with the head assuming height adjustment (z-axis). Particularly large workpieces can also be stationary and the processing head travels in all dimensions e.g. in a portal system.

Systems where the processing head moves in all directions are called "flying optics systems." In 3D applications, the workpiece can be stationary and the laser beam is moved e.g. via robot. It is also possible to move the workpiece in all directions under a fixed laser beam. Moving the beam as well as the workpiece may be required to cut complex structures.

Processing time of a workpiece may be very short in the entire cycle time depending on degree of automation and size of job per workpiece. That is why sometimes more than one processing unit is supplied by the same laser beam source where the laser beam can be switched from one station to another of several different stations, see Fig. 19.

# Laser processing of materials.

Laser beams are used in cutting, welding, and also in surface processing techniques such as hardening, remelting, and removal. The temperatures required for igniting, melting, and vaporising the material can be achieved by focusing the laser beam in a very small focal spot using a lens or mirrors of the processing head.

The focal spot is positioned at varying heights relative to the workpiece e.g. at the upper surface of the workpiece when laser cutting with oxygen, in the workpiece during laser welding or close to the underside of the workpiece in laser cutting with nitrogen. One can, though, deviate significantly from these general rules when certain materials, the desired production quality, the production process or the available beam intensity mandate a different focal position.

Focusing can be entirely unnecessary in hardening and other surface treatment processes where the laser beam is unfocused and processes a large surface per operation.

## Laser cutting

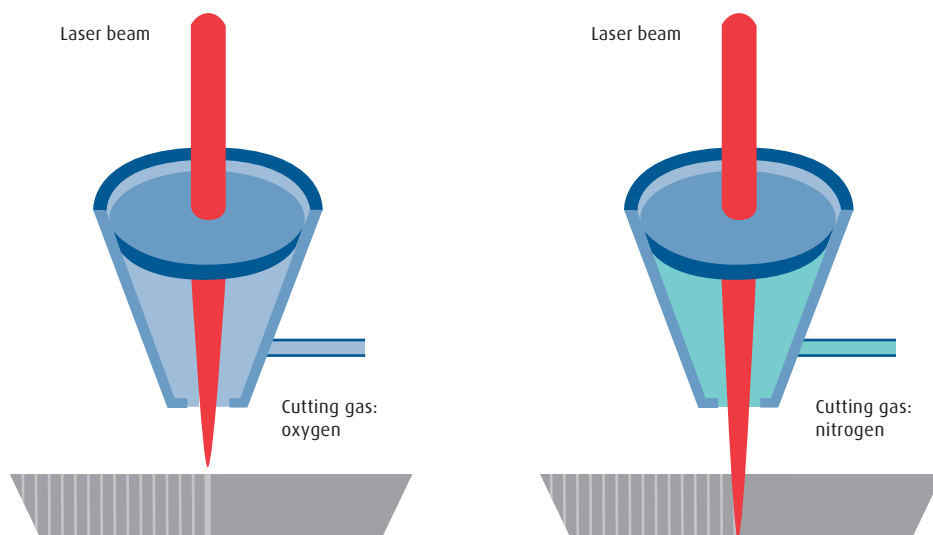
In laser cutting, we principally distinguish between laser cutting with oxygen and laser cutting with a non-reactive gas like e.g. nitrogen or argon. Cutting quality is exceptionally high here (so-called "laser quality"): precise contours, parallel cutting edges, little roughness of cutting surface, no adhesions (burrs), no caving, etc.

Laser sublimation cutting tends to be used more on non-metals. Please refer to the Laser Cutting brochure for further notes and information.

### Laser cutting with oxygen

Similar to oxy-fuel cutting, in laser cutting the workpiece is heated to ignition temperature directly by the laser beam and then burned in an oxygen jet, see Fig. 20. High cutting speeds on sheet metal with thickness between 1mm (0.040 in.) to over 25mm (1 in.) are attained as a result of the exothermic reaction and the additional generation of energy. Laser cutting with oxygen is primarily used for unalloyed and low-alloyed steels. The purity of the cutting oxygen used is reflected directly in the attainable cutting speed.

**Fig. 20: The principle difference between laser cutting with oxygen and laser cutting with nitrogen**



#### Laser cutting with nitrogen

When cutting with nitrogen, the energy needed to melt the workpiece must be provided fully by the laser beam, with the non-reactive gas jet merely serving to blow out the melt, see Fig. 20.

Cutting stainless steel in the thickness range of less than 1mm (0.040 in.) to 25 mm (1 in.) and the cutting of other high-alloy steels and nonferrous metals constitute the main field of application. Here, stainless steels are cut with high-purity nitrogen which maintains the corrosion resistance of the material. Certain nitride forming materials like titanium and zirconium can only be cut with argon in argon atmosphere.

Mild steel is also cut with nitrogen occasionally if the oxide layer which forms during cutting with oxygen must be avoided e.g. for a subsequent painting or powder coating procedure.

#### Laser cutting with air

Cutting of nonmetals with air has been around for a long time. It has not found many applications with regard to cutting of metals.

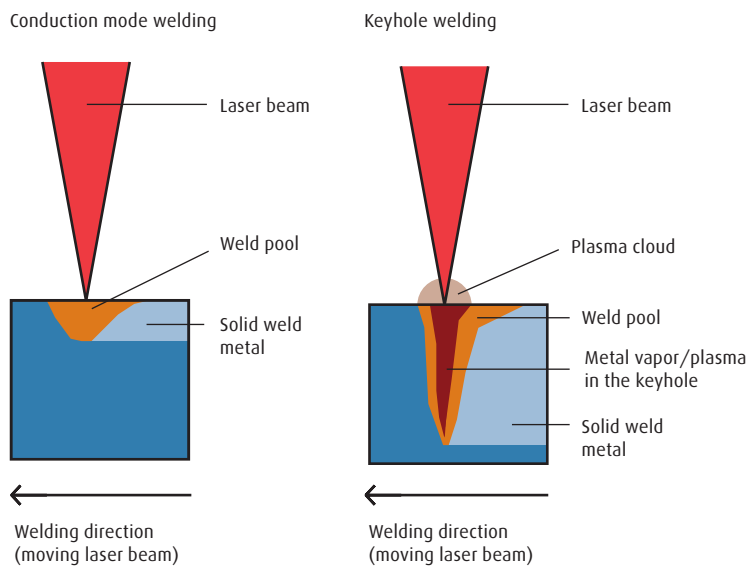
The main reasons are that, first of all, cut quality is generally inferior to the quality achieved with oxygen and nitrogen, especially when cutting material thicker than 1.5mm (0.060 in.). Secondly, the lifetime of the focusing lens is generally shortened due to contaminants (oil, moisture, particles) which are always present in shop air. Last but not least, changing air quality would result in frequent parameter adjustments, which are generally disregarded especially if the machine is supposed to run unattended or in a light-out cycle. However, in some cases cutting with air can meet the required cut quality.

Nevertheless, thorough calculations should include compressed air (electricity, maintenance, spare parts for the compressor), optics, system shut-down and production failure rate.

#### Laser sublimation cutting

The material is vaporised spontaneously in laser sublimation cutting. This method is used e.g. for cutting wood or fabrics. In metal processing, very high intensities, which could only be provided using super-pulse operation, would be needed. The method is only used in special cases due to the low feed rate it is associated with.

**Fig. 21: The principle difference between laser welding without a keyhole (heat conduction welding) and with a keyhole (deep penetration welding)**



## Laser welding

Two or more materials are usually joined in laser welding. Depending on the thickness of the material, a flat, broad weld seam may be sufficient, like the one produced in heat conduction welding with lower power/intensity lasers, see Fig. 21. If intensity in the focus is sufficiently high, a keyhole is formed that enables deep penetration by the laser beam (so-called "deep penetration welding"), so that thicker materials can be welded, see Fig. 21.

Formation of a plasma cloud over the welding spot that can absorb and deflect laser radiation is associated with the forming of the keyhole. The higher the intensity of laser radiation and the thicker the resulting plasma cloud is, the stronger absorption and deflection of the laser radiation by the plasma cloud will be.

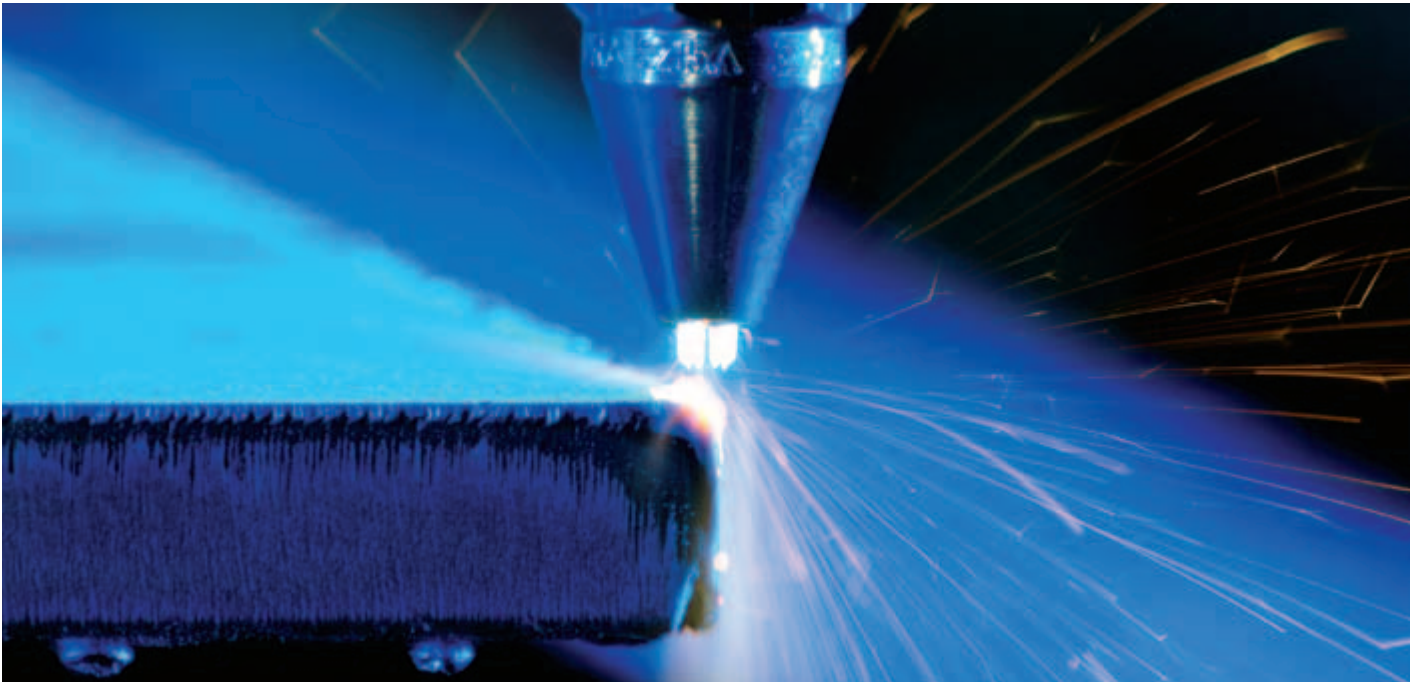
The thickness of the plasma cloud can be influenced by the welding gas. Helium reduces the plasma cloud, argon in turn causes the plasma cloud to expand. The welding gas also serves to protect the welding area, with the heavy and inert argon ensuring that air in the welding area is displaced effectively (flat position). By contrast, helium is a very light, inert gas by comparison that rises from the welding area easily. Both gases are used as a welding gas mixture (3 kW and higher in CO<sub>2</sub> lasers) if laser radiation and intensity are high in order to meet both requirements for the welding gas, namely good blanketing of the weld and plasma reduction. Refer to the Laser Welding brochure for further notes and information.

## Surface treatment with lasers

We distinguish between several different processes in surface processing such as laser transformation hardening, surface modification, laser alloying, and laser coating. Hard layers of a precisely defined width and depth can be produced in transformation hardening. Surface modification can refer to e.g. remelting or tempering.

During alloying, gaseous materials or solid materials are brought into the surface in order to selectively change properties of the surface layer. When coating, a layer is applied to a workpiece in order to improve corrosion resistance or wear resistance. Argon is the most commonly used shielding gas in these processes, which are often associated with lower intensity of an unfocused or defocused beam. Refer to the Laser Welding brochure for further notes and information.

## Laser processing in competition with other technologies.



Lasers and laser materials treatment is a relatively new technology exhibiting advantages over existing technologies like for example flexibility of power adjustment and precision of energy input into the material to be treated. On the other hand, the investment and capacity utilisation required may pose a disadvantage. A laser unit is not a universal tool that can perform all of the tasks in a company economically. Today it is still important to determine the production quality demanded and how that demand can be met with the best economic efficiency. Here, laser technology is certainly one of a number of options.

### Thermal cutting and mechanical cutting

Mild steels within a sheet metal thickness range of up to 10mm (0.40 in.) are predominantly processed in the manufacturing industry. The thermal cutting methods of oxy-fuel cutting, plasma cutting, and laser cutting in addition to the mechanical processes of punching, nibbling, shearing, and water jet cutting are available here. Lasers with their special advantages, such as cutting speed and cutting quality, are tools with no wear and tear, which can especially excel within the sheet thickness range up to 15mm (0.6 in.) and over and position themselves well compared to all other methods including plasma cutting when it comes to stainless steel processing as a major emphasis. In punching, a special tool is needed for each contour element, which is not economical unless a larger series of uniform contour elements are being processed. This is where lasers as a single-head unit or dual-head unit offer much greater flexibility, so that punching is increasingly being pushed out of the market.

When a decision is made in favour of a laser unit, the cutting process itself is often not the only thing taken into account, also the overall production chain is considered. In that respect the laser unit e.g. can; reduce preliminary work or follow up work, perhaps make other steps in production partly superfluous or create entirely new perspectives due to filigree structures and precise contours. More than 40,000 systems installed worldwide speak for themselves. Capacity utilisation and tooling should be analysed critically when making preliminary considerations in favour of or against a laser unit. Minimum capacity utilisation should generally be guaranteed and loading should be more or less automatic, depending on the parts spectrum, in order to permit longer effective processing times by the laser unit.



## Welding

When it comes to joining processes, we could list many more methods, but the laser is predominantly forced to compete against methods of welding technology that can be mechanised, such as the MIG, MAG, TIG, plasma, and electron beam welding processes. We could also mention flame welding here, although it does not represent any real competition. There are numerous interesting laser applications in laser welding, but it would be wrong to talk about a breakthrough like that in the field of cutting.

Actually, though, lasers are their own worst enemies here: The tiny energy beam requires very precise seam preparation, it would pass over common joining gaps with no transfer of energy. The solution to this problem is precise seam preparation (almost no gap) and labour-intensive clamping technology. Another “solution” represents the combination of laser welding and shielded gas welding in a so-called hybrid process. Here, the shielded gas method makes sure that the seam flanges are processed and delivers the additional material; the laser permits deep penetration, and welding speed is significantly higher than when using shielded gas welding on its own.

Existing welding standards form another obstacle on the path to lasers as universal tools. For example, the precise energy beam produces high grades of hardness at high welding speeds and corresponding cooling rates, but in a much narrower range than when conventional welding methods are used, so that existing limit values need to be reconsidered. TTT diagrams and mechanical-technological test procedures are geared to cooling rates and seam widths of conventional welding methods and are barely suited for laser seams.

There are completely new applications that have been made possible by lasers, such as tailored blanks welding. These patchwork sheet metal boards made of sheets of varying thicknesses and composition are formed into e.g. a car door after laser welding, with the material strength being selected in accordance with the transfer of force. No other process permits productivity and formability of seams matching those of laser welding.

## Notes on safety.

Lasers are associated with potential sources of hazards, such as laser radiation, electric power supply and by-products, resulting in laser materials processing that require special care and corresponding safety systems. Gas cylinders, cylinder bundles and tanks are normally used for supplying gas and also need to be handled prudently and require appropriate accident prevention measures.

### Laser radiation

Lasers used in materials processing radiate in the infrared or ultraviolet spectra, to the effect that they are not visible to the human eye, see Fig. 22. That is why a HeNe laser or a laser diode, both low-power lasers that radiate in the visible spectrum, are switched into the beam path when equipping a laser machine.

The intensive laser light of the materials processing laser is especially dangerous to the eye. CO<sub>2</sub> laser radiation is absorbed by the cornea, YAG laser radiation and fibre laser radiation penetrate through to the retina which can be destroyed irrevocably by relatively little radiation. Misdirected laser radiation can come directly from the laser and threaten the eyes as a result of a faulty parameter setting, an opened cover, a displaced mirror, etc. Other hazards include skin burn or inflammation from combustible materials as a result of misdirected laser radiation.

The greatest hazard, though, usually stems from reflected laser radiation. As you will recall: The major share of the laser radiation is reflected by cold material first (Fig. 8). To this we can add reflections of workpiece edges, as a result of turbulence in the weld pool, etc.

Misdirected radiation and reflections must be blocked off. That is why the law stipulates that the laser beam and the work zone must be in an

enclosure; beyond that, all those present and the machine operators in particular should wear protective goggles that are appropriate for the laser radiation being used.

YAG laser radiation and fibre laser radiation are far more dangerous to the eye and require special protective measures and approved safety goggles. Standard protective goggles made of glass or Plexiglas are not suitable at all, as glass and Plexiglas allow YAG laser radiation and fibre laser radiation to pass through.

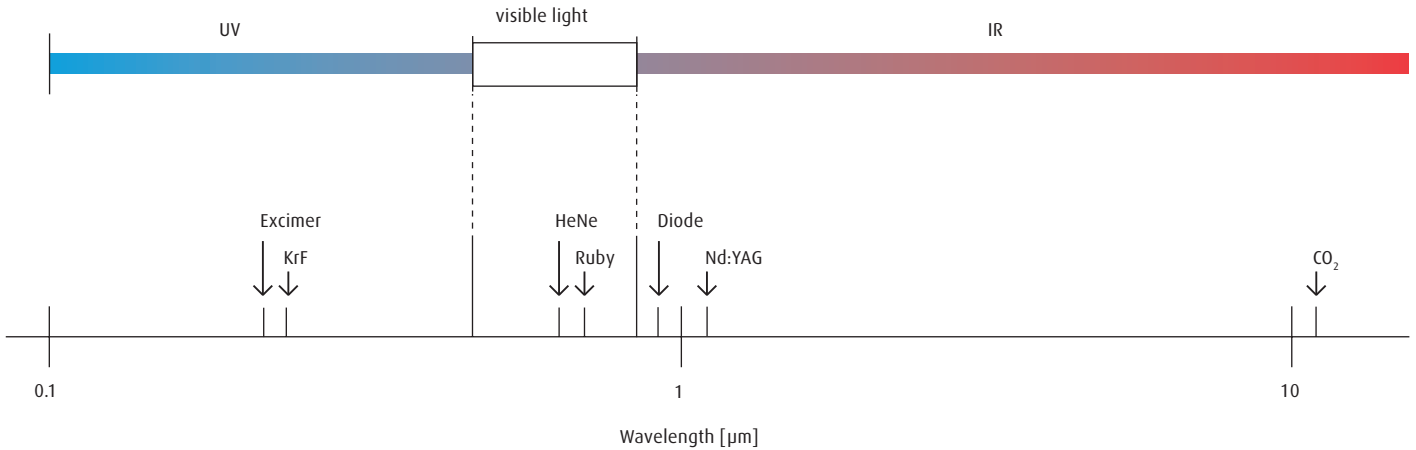
### Electrical power supply

Laser units contain current-carrying and storage components and parts. There is a threat of burns, shock, or death as a result of an electric shock if the enclosure of a laser is opened without cutting the power and discharging certain elements. Therefore, service and maintenance of lasers should always be performed by authorised personnel only.

### Cutting and welding emissions

Dust and smoke that are hazardous to health and dependent on the respective materials being used can occur in laser welding and particularly in laser cutting. Therefore, it is important to always extract fumes and dust from the work zone and constantly provide sufficient fresh air. Cutting plastics is especially critical, as corrosive and toxic gases can be formed. They must be extracted and transported to the outside of the building. When laser cutting plastics and metals in one laser unit, the extraction filters must be replaced every time the material is changed in order to prevent an explosion.

Fig. 22: The spectral ranges of light and different lasers



## Gases and gas supply

Gases for laser materials processing are supplied in a gaseous form in gas cylinders or cylinder bundles, or in liquid form in cryogenic vessels, or, as applicable, in a tank. Gas cylinders and cylinder bundles may be stored in well ventilated places only. Cylinders must always be secured so that they cannot fall over as this can cause injury or damage to the cylinder valve.

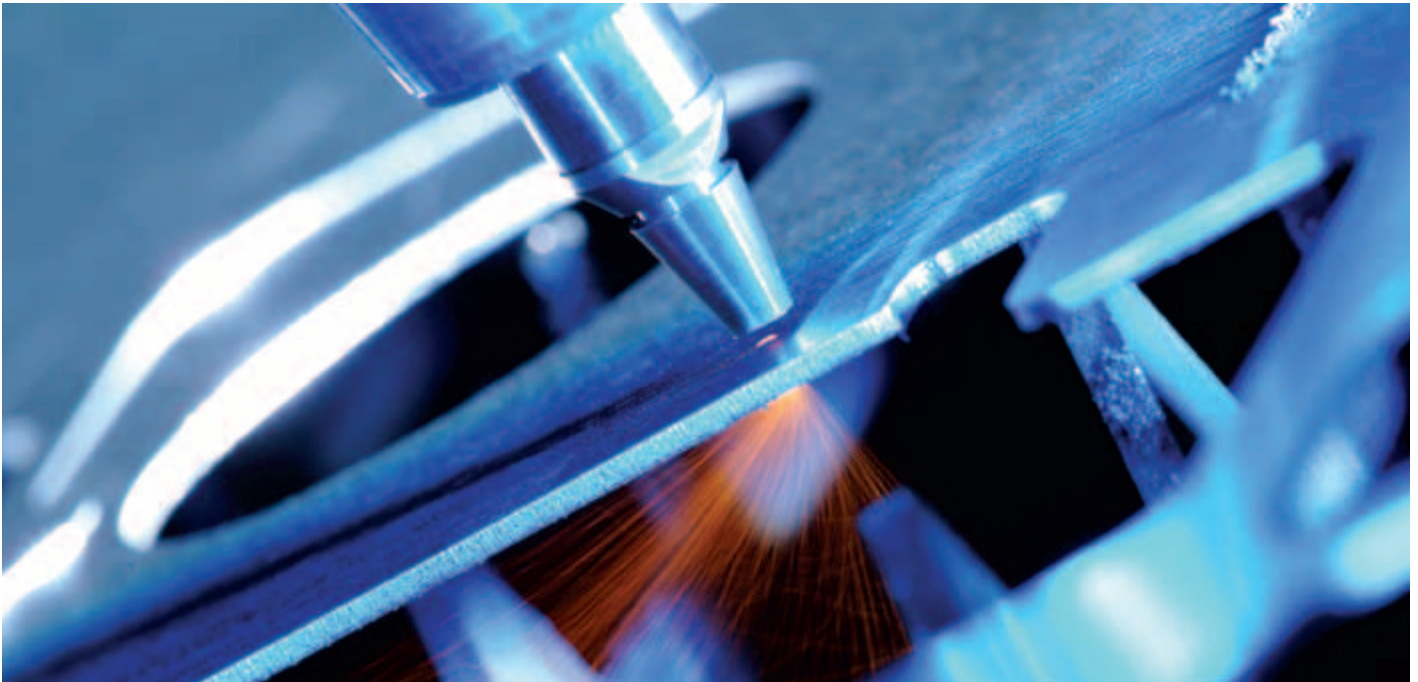
When gas is being withdrawn, pressure must be decreased to operating pressure, which can be done using the corresponding cylinder pressure regulator and/or point-of-use regulators provided. They must be suited for the respective purity of the gas being used and opened slowly in order to avoid a pressure shock that can damage subsequent installations. The cylinder must be resealed when work is finished. Pressure regulators should only be connected and replaced by authorised personnel. Safety valves settings and safeguards should not be changed at all.

The gases themselves are contained in the air we breathe, so that they are harmless as such. Nevertheless, the oxygen concentration in ambient air should not be changed. A reduction of the oxygen level can lead to fainting and even, in extreme cases, to death as a result of suffocation, and an oxygen enrichment significantly increases the risk of explosion. For example, a change in oxygen concentration can occur when cutting with oxygen (enrichment) or nitrogen (displacement) in a confined space that is not exhausted and provided with sufficient fresh air.

Carbon dioxide is a heavy gas that can collect in basins and basement rooms and then displace respiratory oxygen. Therefore, attention should be paid to effective extraction or, as applicable, good ventilation when carbon dioxide is being used as a process gas.

**Please contact Linde for additional safety information.**

## Literature.



With the Linde LASERLINE® programme we offer our customers a complete package consisting of the appropriate gases, a customised gas supply, and comprehensive customer service.

For a selection of other LASERLINE® Technical brochures please contact your local Linde representative.

Laser gases and gas supply systems.

Laser cutting.

Laser welding.

Laser in material processing – Evaluation of cost efficiency.

### Authors

Dr.-Ing. J. Berkmanns,  
Linde Gas LLC, Cleveland, USA

Dr.-Ing. M. Faerber,  
Linde AG, Division Linde Gas, Unterschleissheim, Germany

### Date

June 18, 2008

### Picture credits

Image on page 16, IFSW, Stuttgart, Germany

# BOC – turning ideas into solutions

BOC is a member of The Linde Group, a leading global gases and engineering company.

BOC is the UK's largest provider of industrial, specialist and medical gases, as well as related products and services. As a leader in the application of technology, we are constantly looking for new ways to provide our customers with high quality products and innovative solutions.

At BOC we help our customers to create added value, clearly discernible competitive advantage and hence greater profitability. To achieve this we have a comprehensive range of products and services, and technical support which can be customised to meet the individual requirements of our clients.

To keep ahead of the competition in today's market, you need a partner for whom quality, service, process and productivity optimisation are an integral part of customer support. We are there for you and with you, helping to build your success.

BOC's reputation has been forged through partnerships – with customers, with relevant regulatory authorities and with key suppliers. In this way, we deliver comprehensive and consistent benefits to you.

**BOC – world-leading knowledge and resources adapted to local requirements.**

## For enquiries please contact:

### BOC

Customer Service Centre,  
Priestley Road, Worsley,  
Manchester M28 2UT

**Tel** 0800 111 333  
**Fax** 0800 111 555  
**Email** [custserv@boc.com](mailto:custserv@boc.com)  
**Web** [BOCOnline.co.uk](http://BOCOnline.co.uk)

### BOC Ireland

PO Box 201,  
Bluebell, Dublin 12,  
Republic of Ireland

**Tel** 1890 355 255  
**Fax** (0)1 409 1801  
**Email** [irelandsales@boc.com](mailto:irelandsales@boc.com)  
**Web** [BOCOnline.ie](http://BOCOnline.ie)

### BOC

The Priestley Centre, 10 Priestley Road,  
The Surrey Research Park, Guildford, Surrey GU2 7XY, United Kingdom

**Tel** +44 (0) 1483 579 857 **Fax** +44 (0) 1483 505 211 **Web** [BOCOnline.co.uk](http://BOCOnline.co.uk)

The stripe symbol and the letters BOC are registered trade marks of The BOC Group Limited. Both BOC Limited and The BOC Group Limited are members of The Linde Group, the parent company of which is Linde AG. Reproduction without permission is strictly prohibited. © BOC Limited 2010